

REV
SH
DWG NO 1666-T

REVISIONS			
REV	DESCRIPTION	DATE	APPROVED

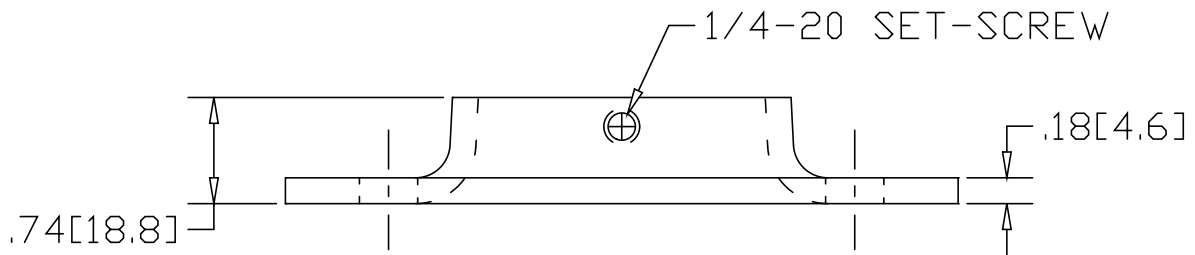
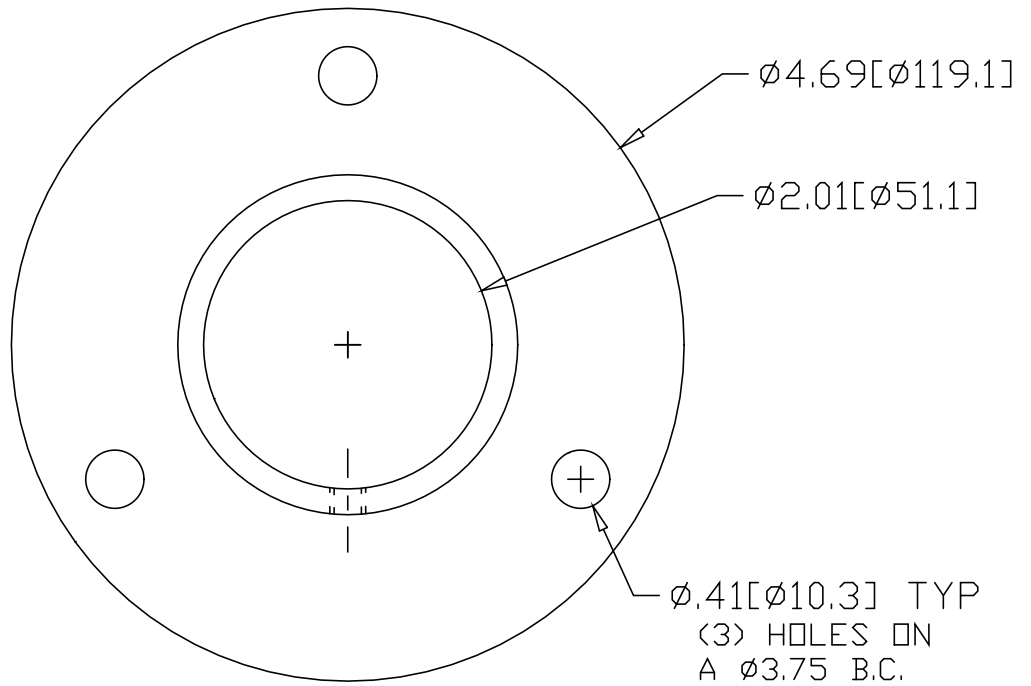

INCHES [MILLIMETERS]

ALTERNATE MATERIAL	PART NUMBER
.190" (3003) ALUMINUM ASTM B-209	1676-T

PART NAME 2" O.D. TUBE EXTRA HEAVY FLANGE W/(3) HOLES AND SET-SCREW			
MATERIAL 7 GA. HPR&D STEEL ASTM A-569			
DATE 3/2/95	WAGNER	R & B WAGNER, INC.	
DRAWN BY RJF			
FINISH MILL			
SIZE A	WEIGHT .81 LBS	PART NUMBER 1666-T	REV