

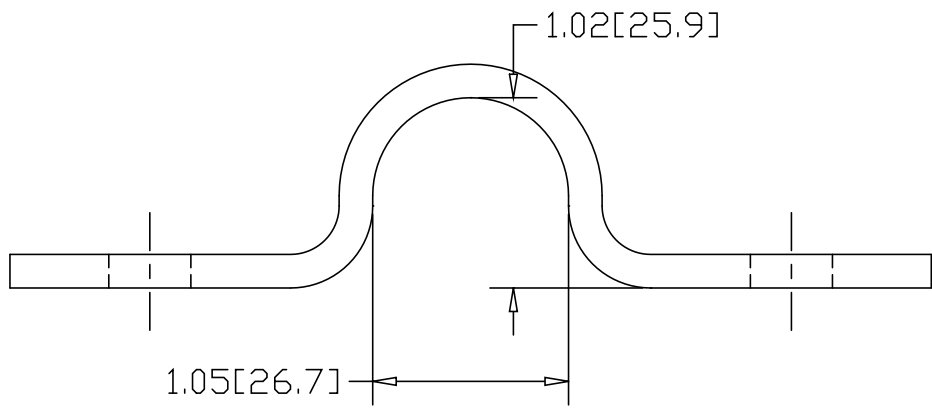

REV
SH
3740
DWG NO

REVISIONS			
REV	DESCRIPTION	DATE	APPROVED

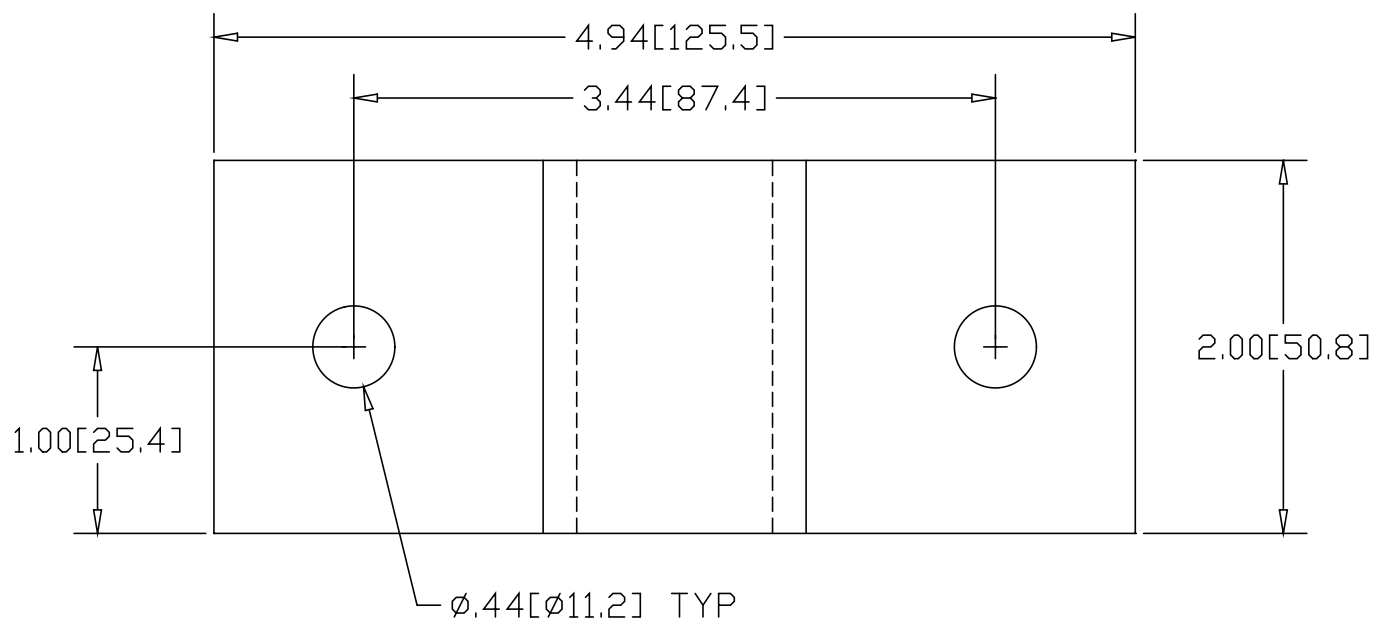

INCHES [MILLIMETERS]

ALTERNATE MATERIAL	PART NUMBER
.190 (3003) ALUMINUM ASTM B209	3740A
7 GA. (304) STAINLESS STEEL ASTM A240	3740-SS

PART NAME 3/4" PIPE (1.05" OD) X 2" WIDE U-BRACKET W/(2) HOLES				
MATERIAL 7 GA. HRP&O STEEL ASTM A569				
DATE 1/13/00	 THE WAGNER COMPANIES R & B WAGNER, INC. AND J. G. BRAUN CO.			
DRAWN BY RJF		SIZE A	WEIGHT .58 LBS	PART NUMBER 3740
FINISH MILL				REV