

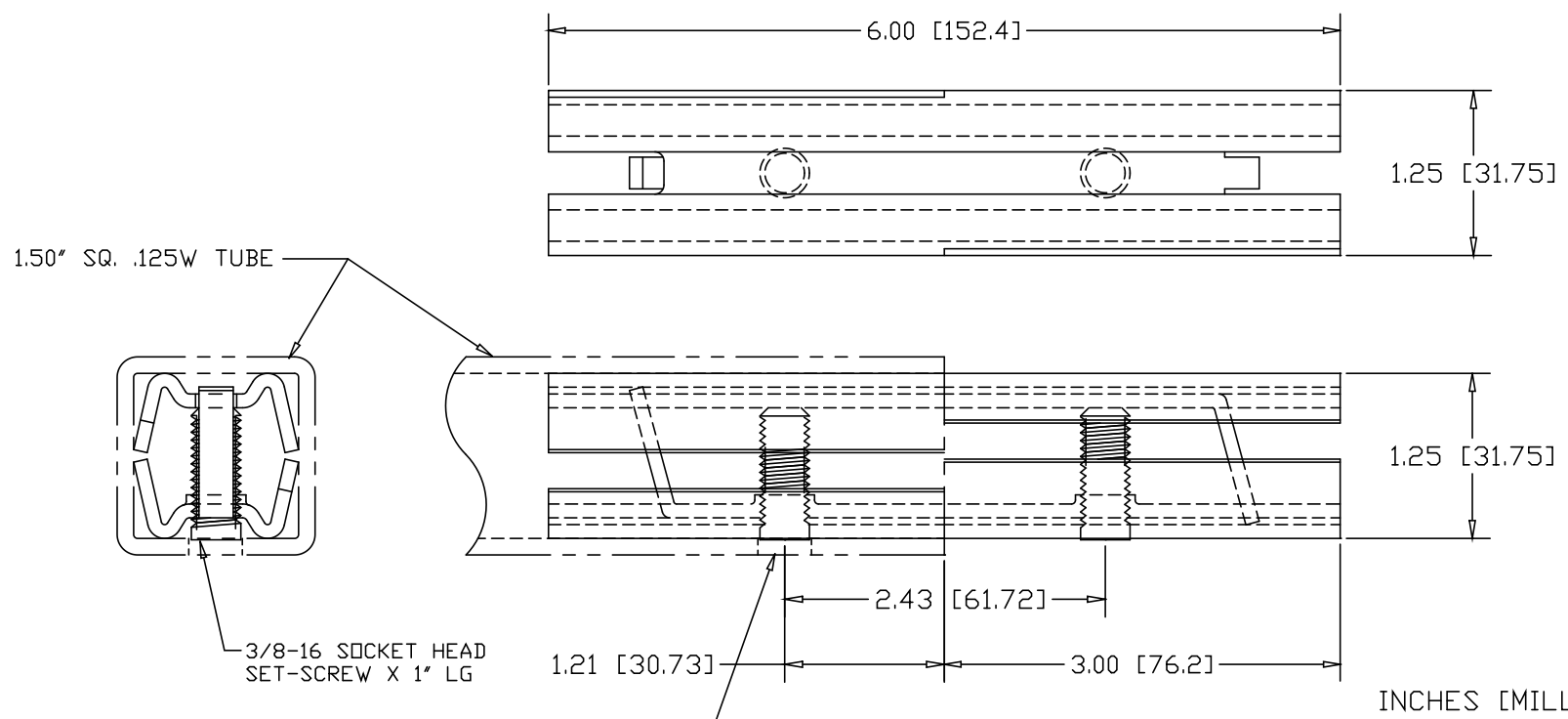

REVISIONS			
REV	DESCRIPTION	DATE	APPROVED



INCHES [MILLIMETERS]

DRILL ϕ .406 HOLE
1.22" IN FROM END
OF EACH PIPE

ALTERNATE MATERIAL	PART NO.
12 GA. STEEL HOT DIP GALVANIZED	G3385-6
12 GA. STEEL ZINC PLATED	PL3385-6
.090 (3003) ALUMINUM ASTM B209	3386-6
.090 (304) STAINLESS STEEL ASTM A240	3387-6

PART NAME		1.50" SQ. .125W TUBE DOUBLE-LOCK SPLICE-LOCK 6" LONG					
MATERIAL		12 GA. HRP&D STEEL ASTM A569					
DATE	9/28/01	 R & B WAGNER, INC.					
DRAWN BY	JAH						
FINISH	MILL						
SIZE	A	WEIGHT	.75 LBS	PART NUMBER	3385-6	REV	