

REV
SH
1662-T
DWG NO

REVISIONS			
REV	DESCRIPTION	DATE	APPROVED

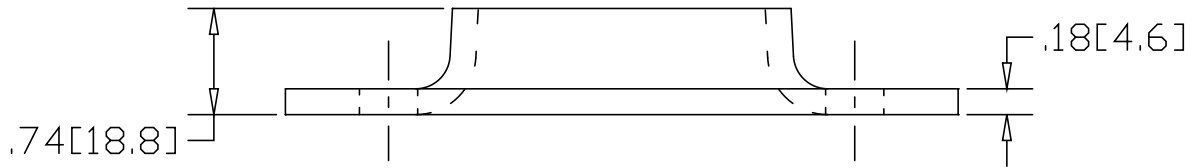
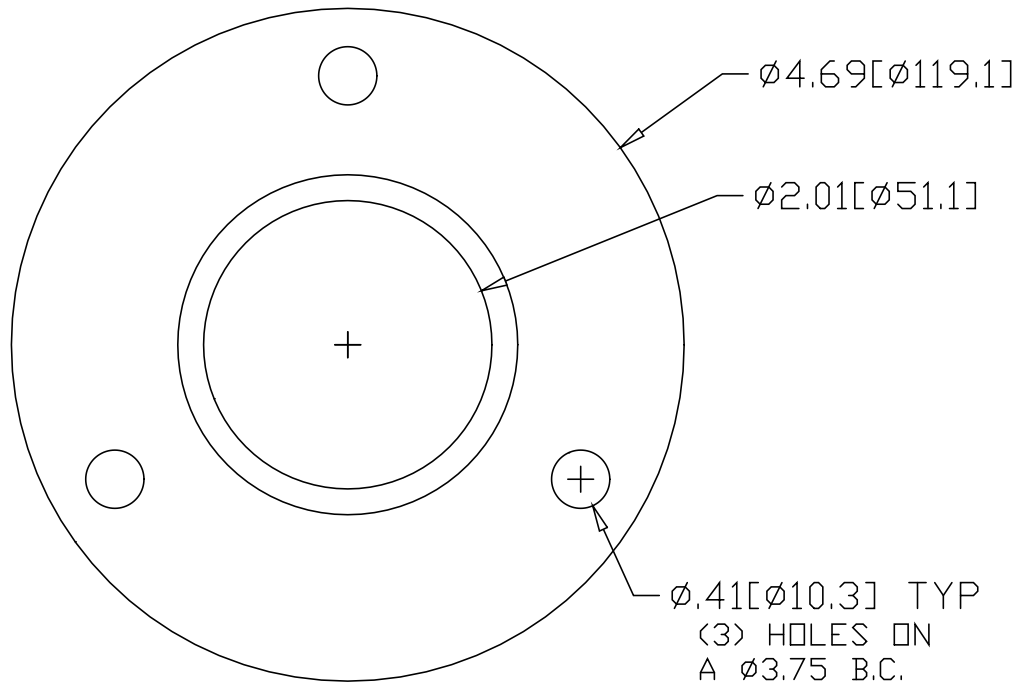

* USE WITH ANCHOR PLATE
 #B1628 IN STEEL
 #B1648 IN ALUMINUM

INCHES [MILLIMETERS]

ALTERNATE MATERIAL	PART NUMBER
.190" (3003) ALUMINUM ASTM B-209	1672-T
7 GA. (304) STAINLESS STEEL ASTM A240	1662-TSS

PART NAME 2" O.D. TUBE EXTRA HEAVY FLANGE W/(3) HOLES			
MATERIAL 7 GA. HPR&D STEEL ASTM A-569			
DATE 3/2/95	 R & B WAGNER, INC.		
DRAWN BY RJF			
FINISH MILL			
SIZE A	WEIGHT .81 LBS	PART NUMBER 1662-T	REV