

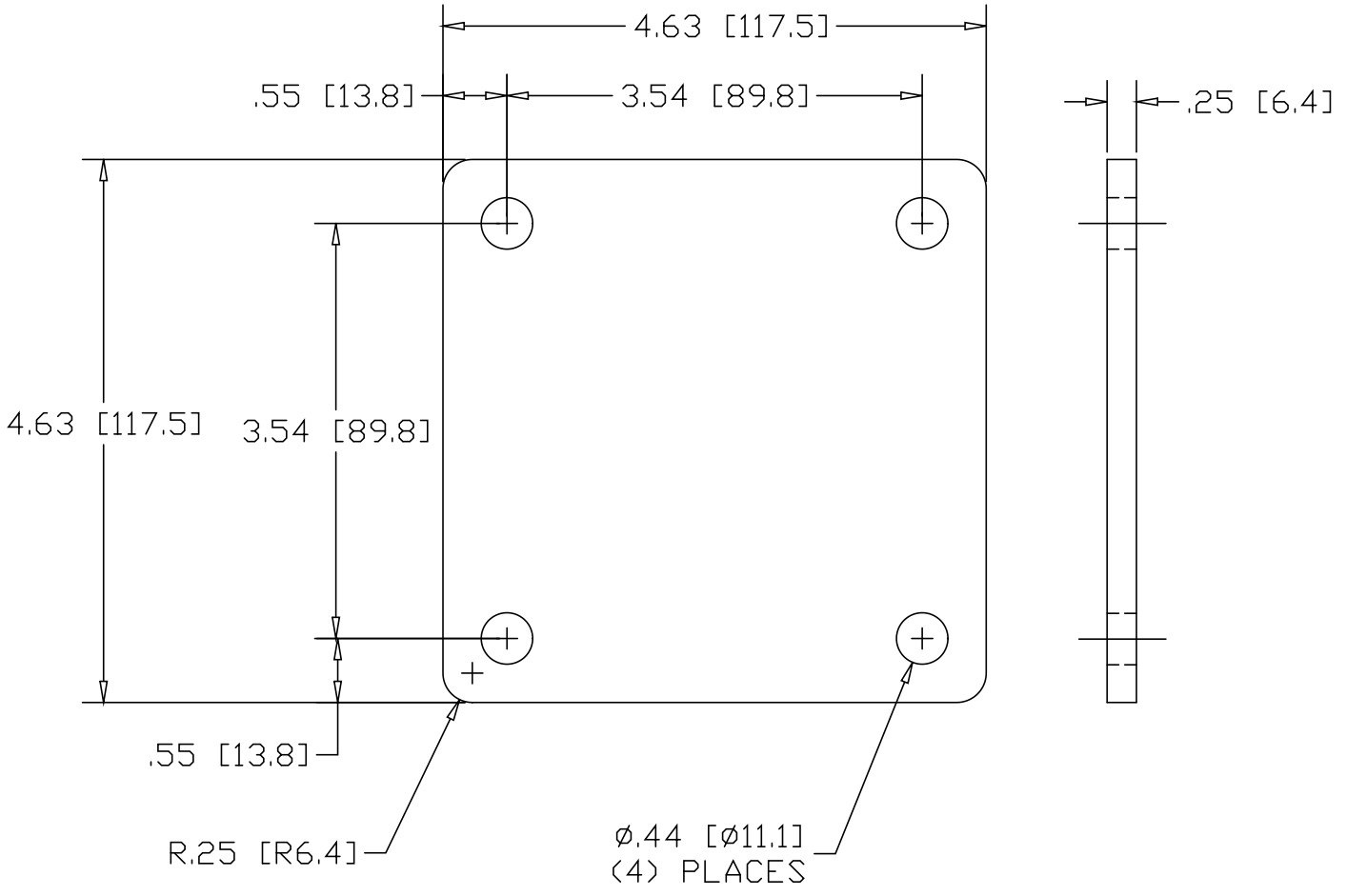

REV
SH
D484H
DWG NO

REVISIONS			
REV	DESCRIPTION	DATE	APPROVED



INCHES [MILLIMETERS]

ALTERNATE MATERIAL	PART NUMBER
.250 (3003) ALUMINUM ASTM B209	D485H
.18 (304) STAINLESS STEEL ASTM A240	D486H

PART NAME 4-5/8" SQUARE PLATE WITH (4) HOLES			
MATERIAL .250 HRP&D STEEL ASTM A569			
DATE 11/20/98		THE WAGNER COMPANIES R & B WAGNER, INC. AND J. G. BRAUN CO.	
DRAWN BY RJF			
FINISH MILL			
SIZE A	WEIGHT 1.52 LBS	PART NUMBER D484H	REV