

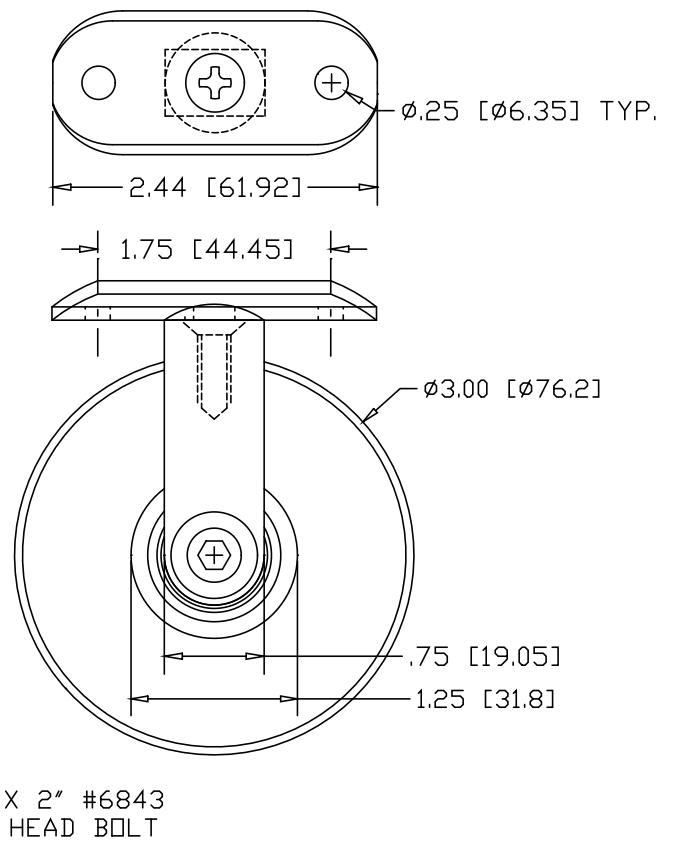

REVISIONS			
REV	DESCRIPTION	DATE	APPROVED
A	REVISED SADDLE	1/20/06	RDC

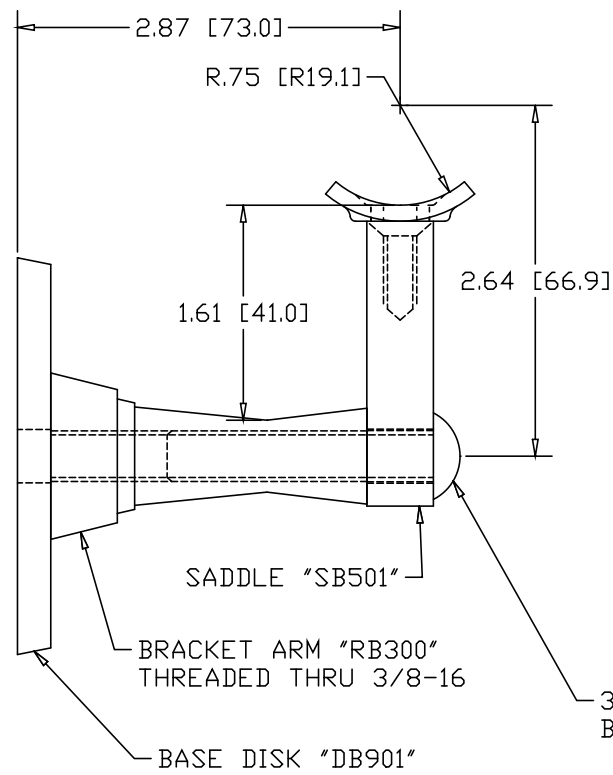

INCHES [MILLIMETERS]

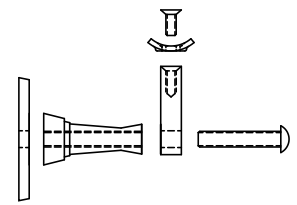

EXPLODED VIEW

PART NAME		MACHINED BRACKET, WALL MOUNT		
MATERIAL		BRASS		
DATE	9/15/03		<b>THE WAGNER COMPANIES</b> R & B WAGNER, INC. AND J. G. BRAUN CO.	
DRAWN BY	RJF			
FINISH	#6 SATIN	SIZE	WEIGHT	PART NUMBER
		A		MB4301W
				REV A