

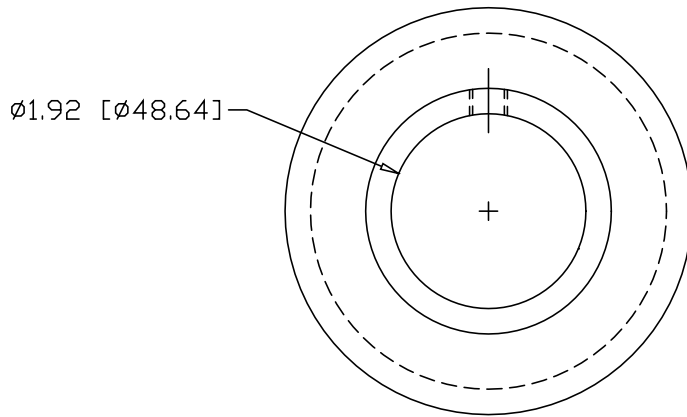

REV
SH
WR260
DWG NO

REVISIONS			
REV	DESCRIPTION	DATE	APPROVED

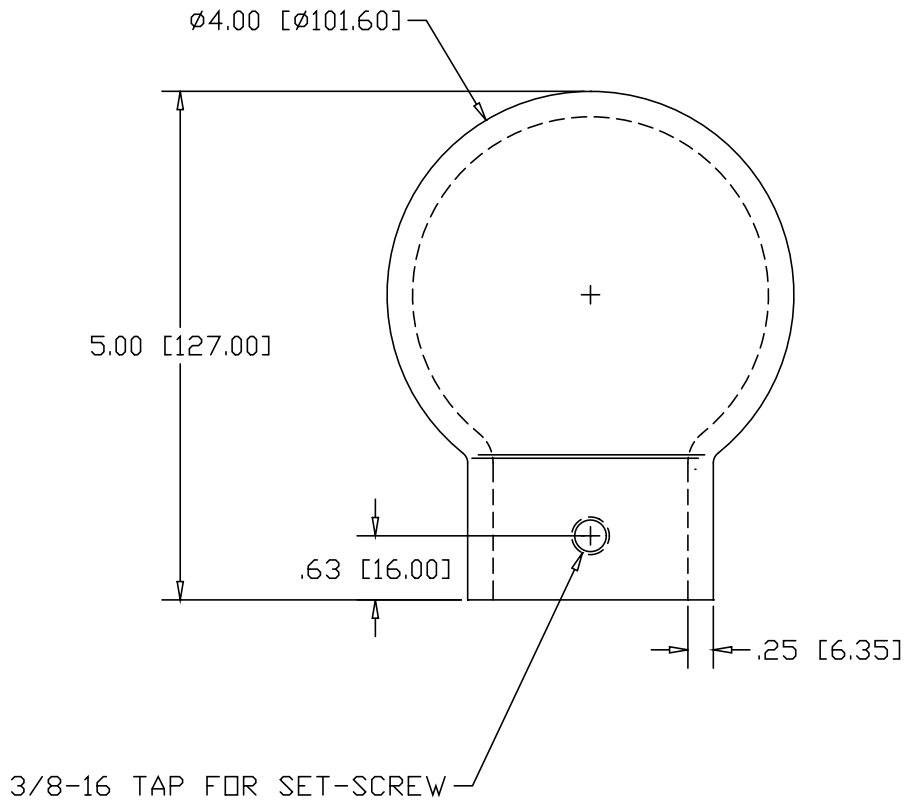

INCHES [MILLIMETERS]

PART NAME BALL FITTING SINGLE OUTLET FOR 1-1/2" PIPE			
MATERIAL CAST ALUMINUM			
DATE 04/19/04		THE WAGNER COMPANIES R & B WAGNER, INC. AND J. G. BRAUN CO.	
DRAWN BY RJF			
FINISH MILL	SIZE A	WEIGHT	PART NUMBER WR260
			REV