

REV  
SH  
4811  
DWG NO

REVISIONS			
REV	DESCRIPTION	DATE	APPROVED

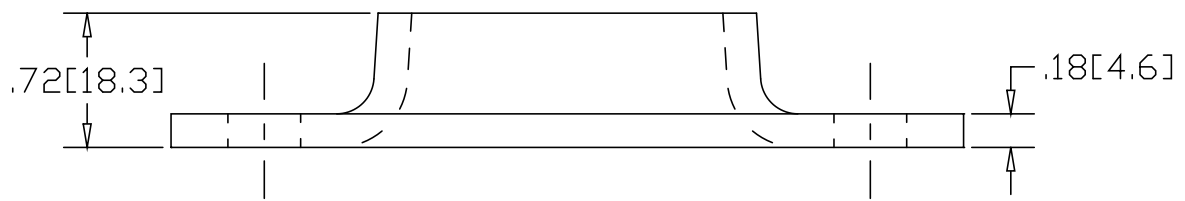
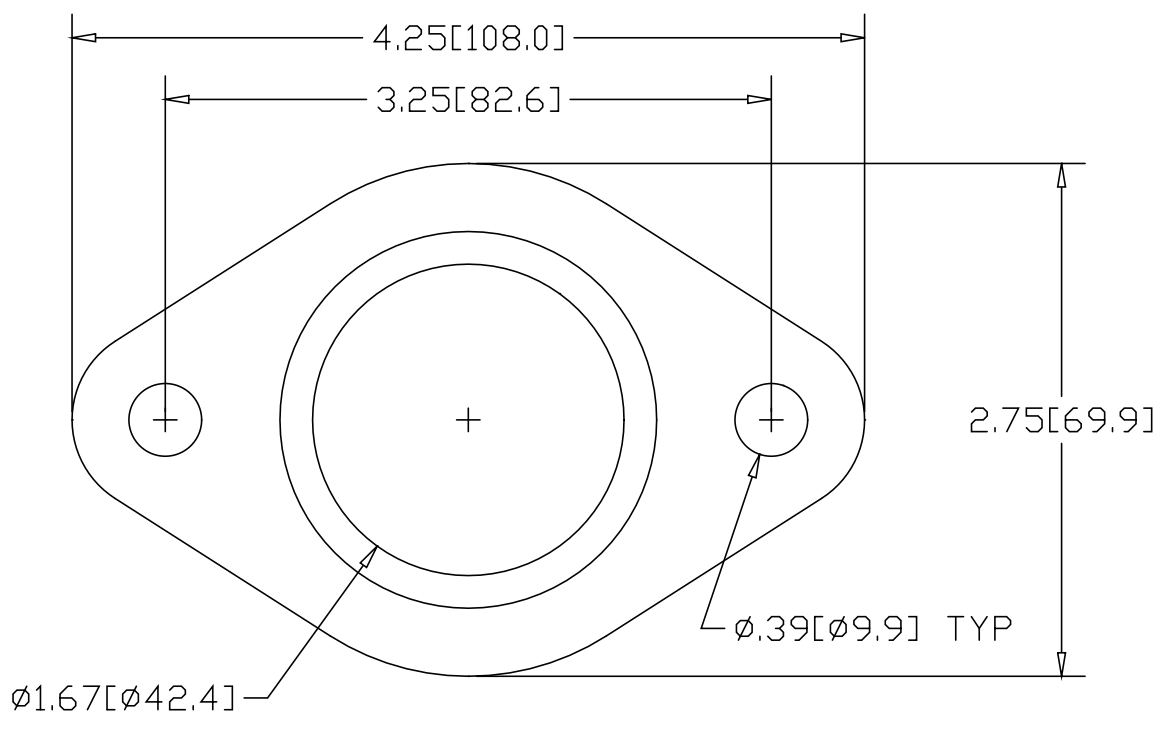

INCHES [MILLIMETERS]

ALTERNATE MATERIAL	PART NUMBER
.190 (3003) ALUMINUM ASTM B-209	4841
7 GA. (304) STAINLESS STEEL ASTM A-240	4871

PART NAME 1-1/4" PIPE SIZE TAPERED FLAT BASE FLANGE WITH (2) HOLES				
MATERIAL 7 GA. HRP&D STEEL ASTM A-569				
DATE 3/21/95				
DRAWN BY RJF				
FINISH MILL	SIZE A	WEIGHT .36 LBS	PART NUMBER 4811	REV