

REV
SH
DWG NO 396

REVISIONS			
REV	DESCRIPTION	DATE	APPROVED

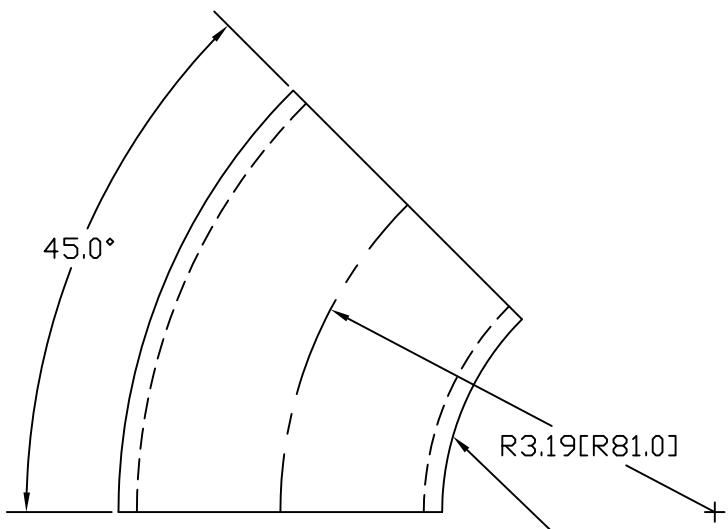

NOTE: UNWELDED SEAM ALONG INSIDE RADIUS

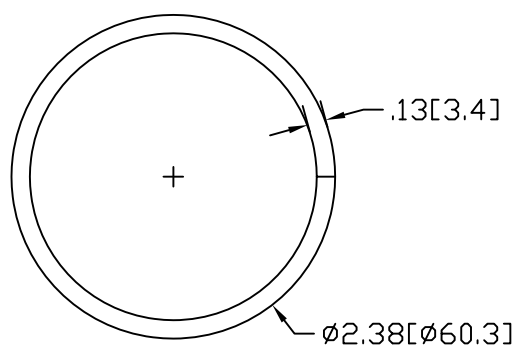

INCHES [MILLIMETERS]

ALTERNATE MATERIAL	PART NUMBER
.125 (3003) ALUMINUM ASTM B209	412-2
10 GA. (304) STAINLESS STEEL ASTM A240	427

PART NAME		2" PIPE SIZE 45° ELL X 2" I.R.		
MATERIAL		10 GA. HRP&D STEEL ASTM A569		
DATE	8/24/95	 R & B WAGNER, INC.		
DRAWN BY	RJF			
FINISH	MILL	SIZE	WEIGHT	PART NUMBER
		A	.69 LBS	396
				REV