

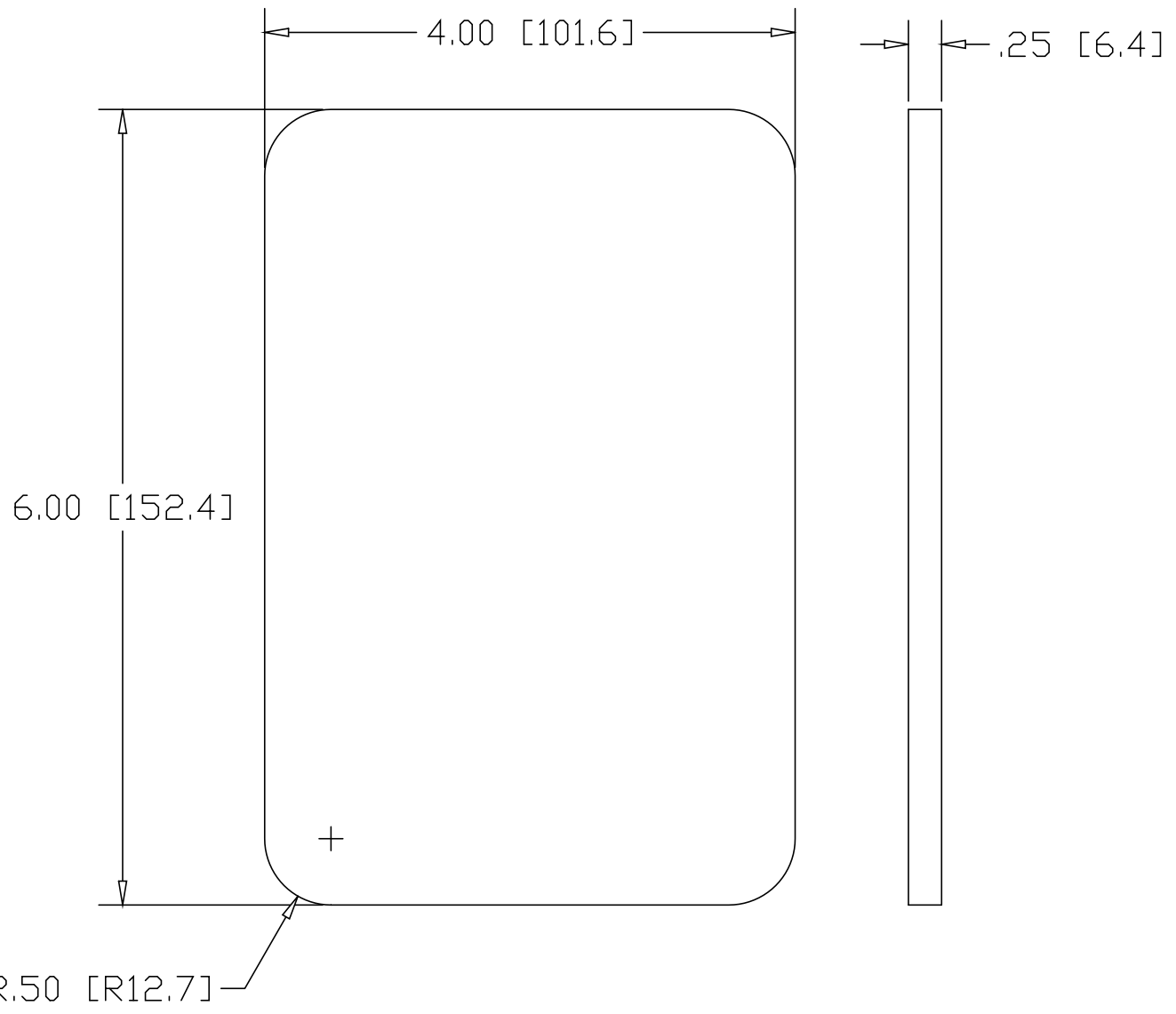

REV
SH
D372
DWG NO

REVISIONS			
REV	DESCRIPTION	DATE	APPROVED



INCHES [MILLIMETERS]

ALTERNATE MATERIAL	PART NUMBER
.190 (3003) ALUMINUM ASTM B209	D373
.187 (304) STAINLESS STEEL ASTM A240	D374
.187 (260) BRASS ASTM B19,B36	D375

PART NAME		4" X 6" RECTANGULAR PLATE WITH RADIUS CORNERS					
MATERIAL		.179 HRP&D STEEL ASTM A569					
DATE	11/20/98	 THE WAGNER COMPANIES R & B WAGNER, INC. AND J. G. BRAUN CO.					
DRAWN BY	RJF						
FINISH	MILL						
SIZE	A	WEIGHT	1.25 LBS	PART NUMBER	D372	REV	