

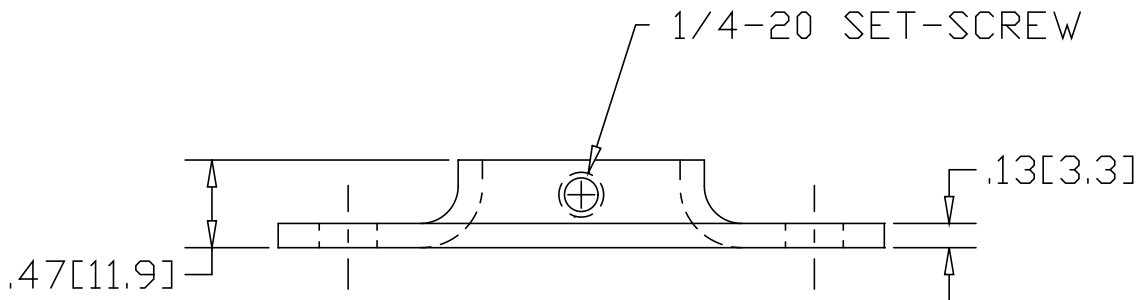

REV  
SH  
614  
DWG NO

REVISIONS			
REV	DESCRIPTION	DATE	APPROVED

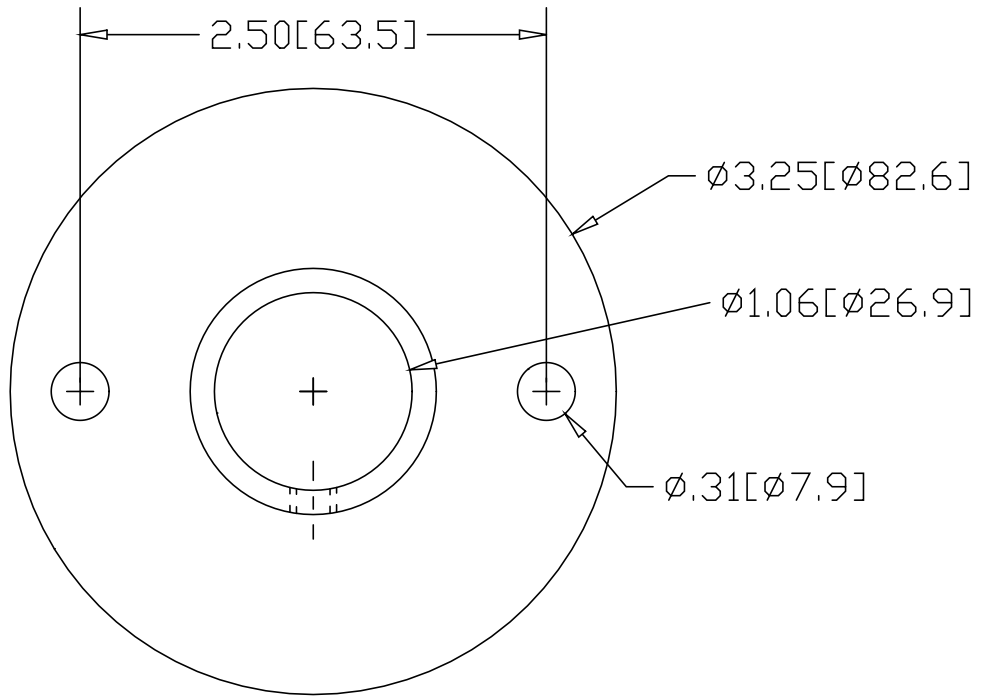

INCHES [MILLIMETERS]

ALTERNATE MATERIAL	PART NUMBER
.125 (3003) ALUMINUM ASTM B209	654
10 GA. (304) STAINLESS STEEL ASTM A240	694

PART NAME 3/4" PIPE FLAT BASE FLANGE W/(2) HOLES AND SET-SCREW			
MATERIAL 10 GA. HRP&D STEEL ASTM A-569			
DATE 1/5/99		R & B WAGNER, INC.	
DRAWN BY RJF		SIZE A	WEIGHT .3 LBS
FINISH MILL			REV