

REV
SH
1151-2
DWG NO

REVISIONS			
REV	DESCRIPTION	DATE	APPROVED

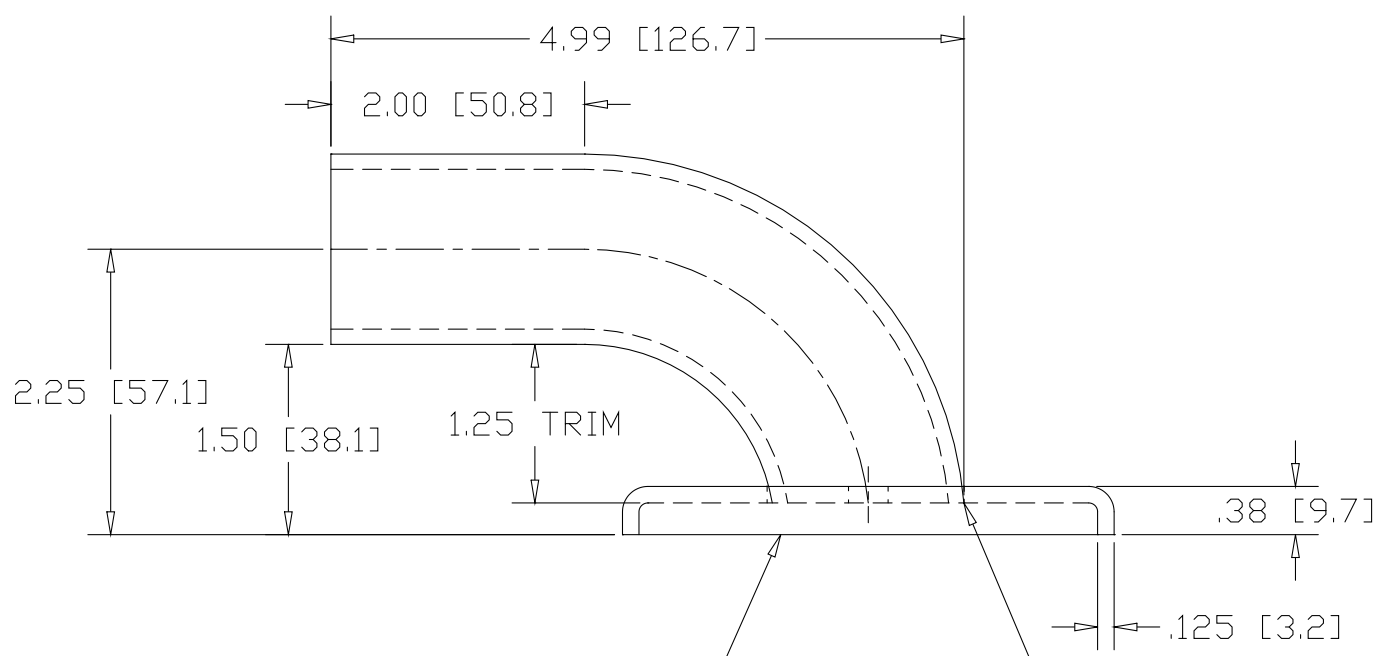
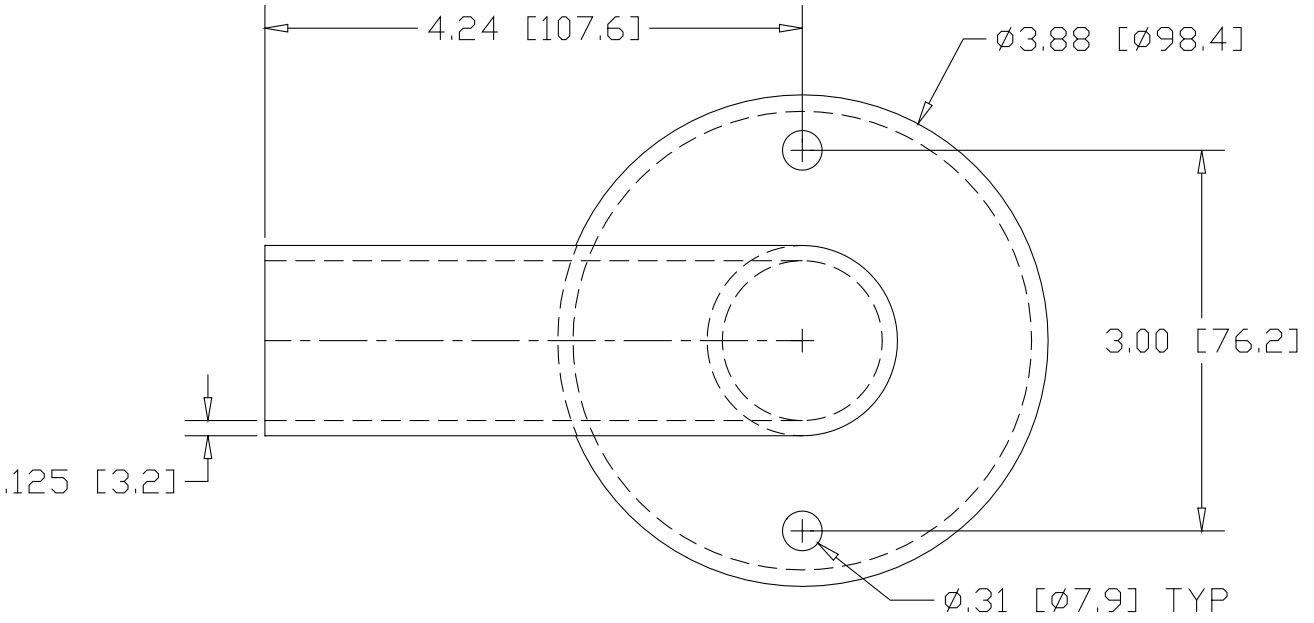

R & B WAGNER
HEAVY FLUSH BASE
FLANGE #2575T

WELD ALL
AROUND

INCHES [MILLIMETERS]

PART NAME 1.50" TUBE SIZE X 2.25CL WALL RETURN W/2 HOLES			
MATERIAL 6063 ALUMINUM TUBE ELBOW, 3003 FLANGE			
DATE 12/30/02		 THE WAGNER COMPANIES R & B WAGNER, INC. AND J. G. BRAUN CO.	
DRAWN BY RJF			
FINISH MILL			
SIZE A	WEIGHT .52 LBS.	PART NUMBER 1151-2	REV