

REV
SH
8047
DWG NO

REVISIONS			
REV	DESCRIPTION	DATE	APPROVED

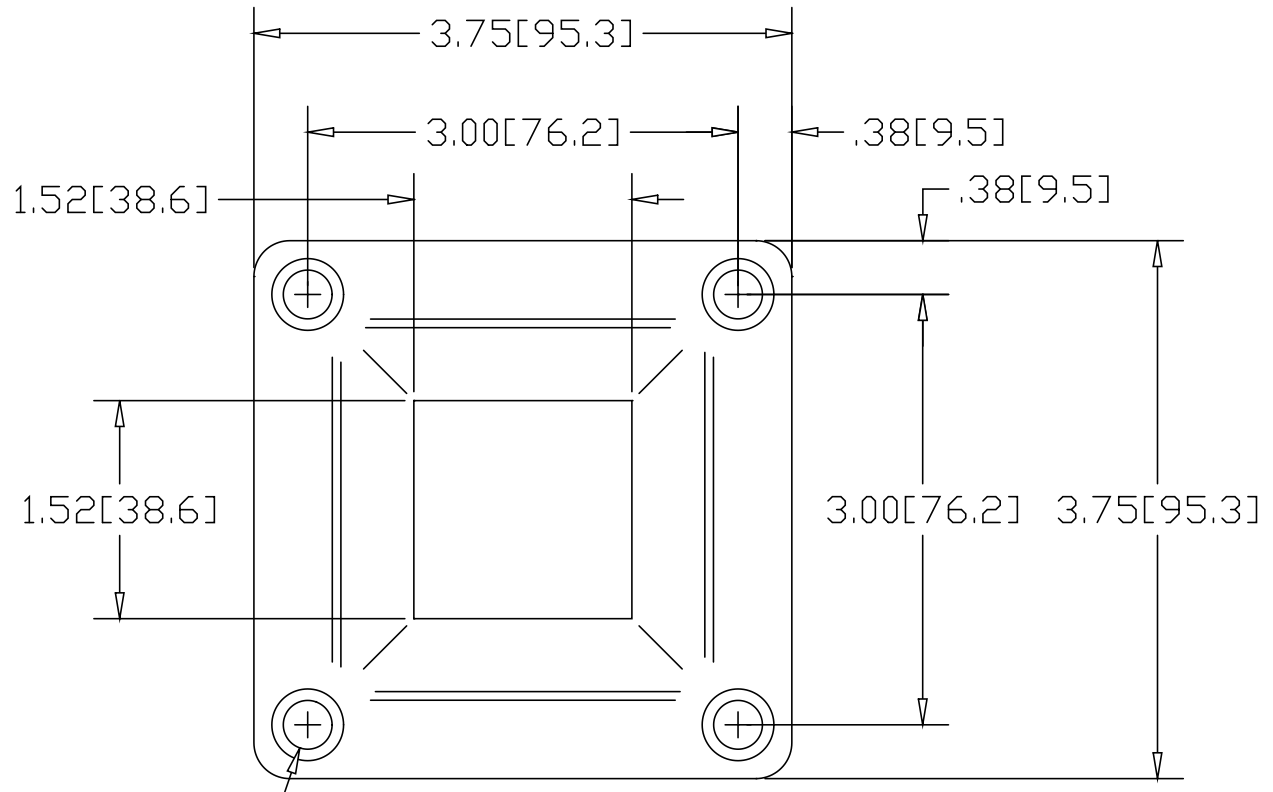

Ø.34 [Ø8.6] TYP
W/C SINK

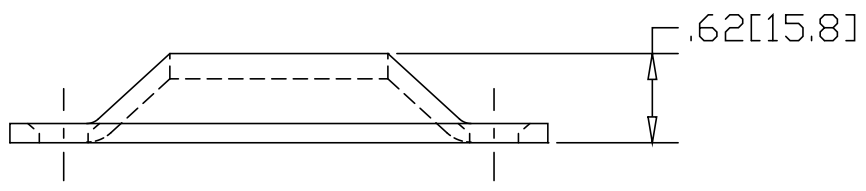

*USE WITH ANCHOR PLATE
#8057 IN STEEL
#8058 IN ALUMINUM

INCHES [MILLIMETERS]

ALTERNATE MATERIAL	PART NUMBER
.125 (3003) ALUMINUM ASTM B209	8048

PART NAME		1.50" SQUARE TUBE FLANGE WITH (4) HOLES	
MATERIAL		10 GA. HRP&D STEEL ASTM A569	
DATE	7/24/96	 R & B WAGNER, INC.	
DRAWN BY	RJF		
FINISH	MILL	SIZE	A
		WEIGHT	.46 LBS
		PART NUMBER	8047
		REV	