

REV A  
SH  
1435  
DWG NO

REVISIONS			
REV	DESCRIPTION	DATE	APPROVED
A	.92 WAS .96, .375 WAS .43	04/07/14	RJF

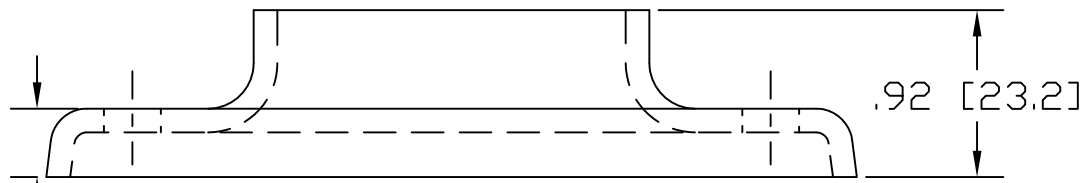
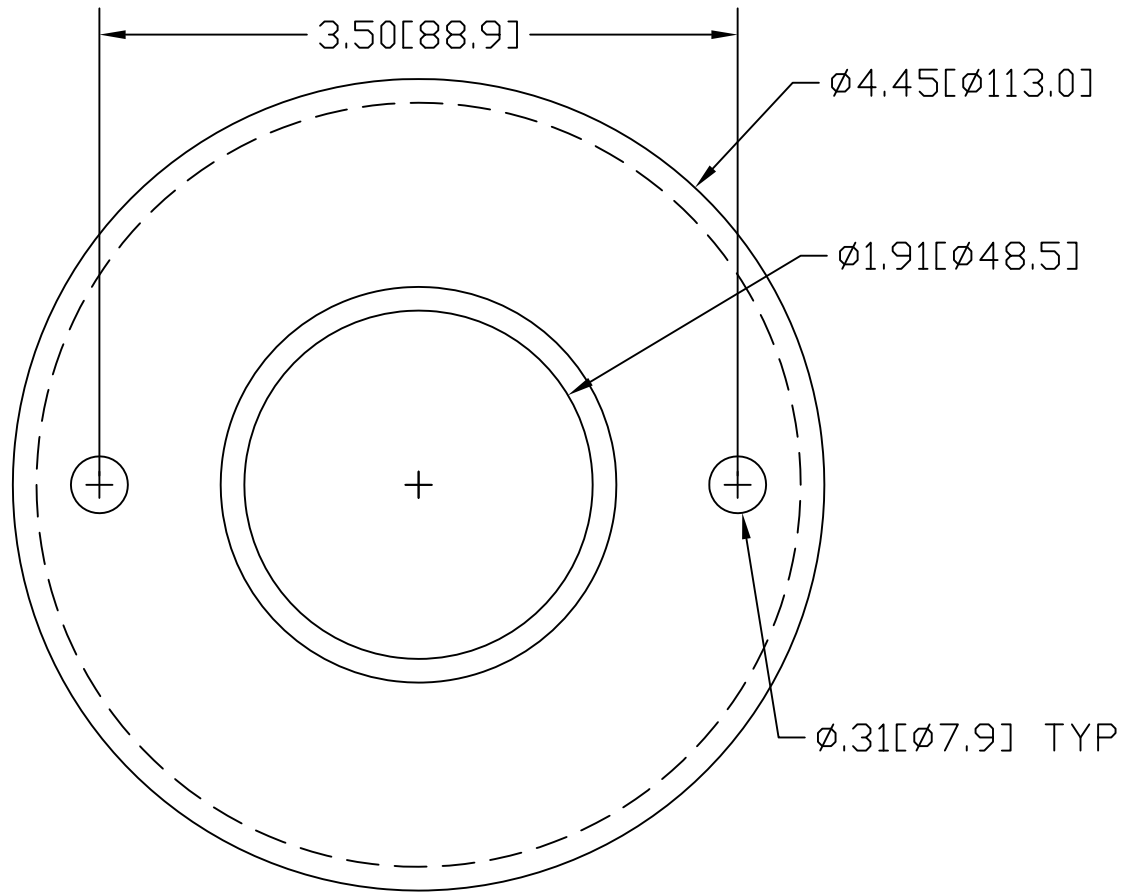

.375 [9.5]

INCHES [MILLIMETERS]

\*USE WITH ANCHOR PLATE  
#B1440 IN STEEL  
#PLB1440 ZINC PLATED STEEL  
#B1540 IN STAINLESS STEEL

ALTERNATE MATERIAL	PART NUMBER
.125 (3003) ALUMINUM ASTM B209	1475
10 GA. (304) STAINLESS STEEL ASTM A240	1535

PART NAME 1-1/2" PIPE HEAVY BASE FLANGE W/(2) HOLES				
MATERIAL 10 GA. HRP&D STEEL ASTM A569				
DATE 9/13/94	 R & B WAGNER, INC.			
DRAWN BY RJF				
FINISH MILL	SIZE A	WEIGHT .64 LBS	PART NUMBER 1435	REV A