

2



1

REVISION HISTORY

REV	DESCRIPTION	DATE
2	Changed red pad to white	11/20/2017
3	PGISO.035 Qty. 2 WAS PGISO.125 Qty. 1	12/20/2018
4	PGISO.090 Qty. 1 WAS PGISO.035 Qty. 2	2/1/2019
5	Added Sheet 2, mechanism details	3/18/2019

PARTS LIST

ITEM	QTY	PART NUMBER	DESCRIPTION
1	1	PGISO60	Brown Isolator, Plastic, Used with Panel Grip, 1/2" Glass
2	1	N/A	Panel Grip Assembly, see sheet 2
3	1	PGISO.090	Isolator HDPE White/PSA 3M 468MP One Side .090 Inch X 1.25 Inch X 2.5 Inch Printed

B

B

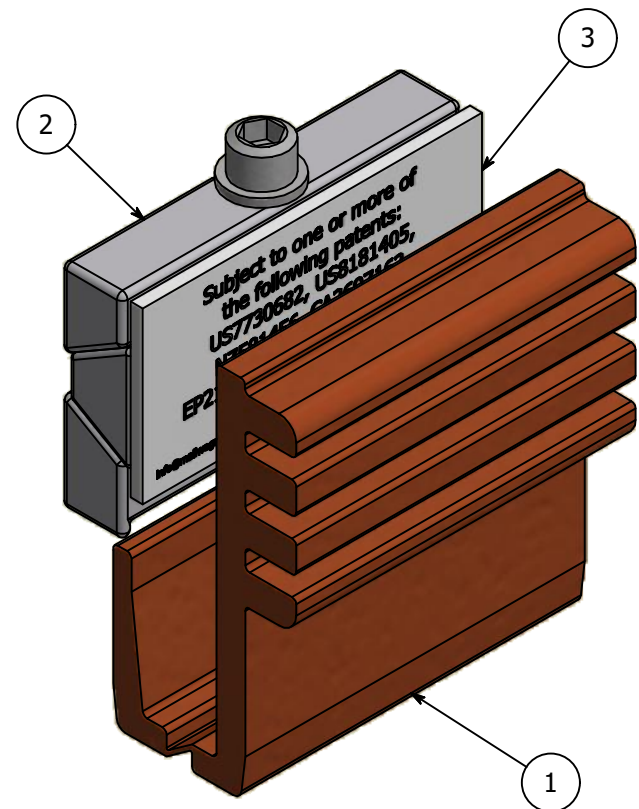
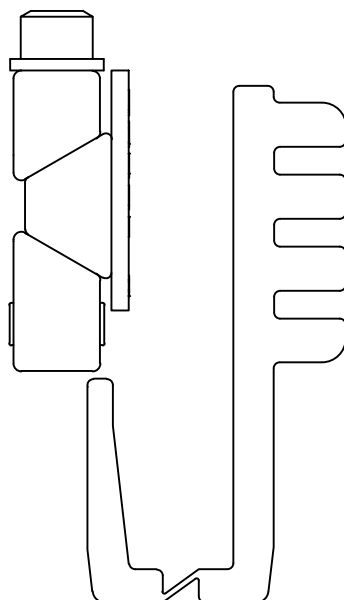
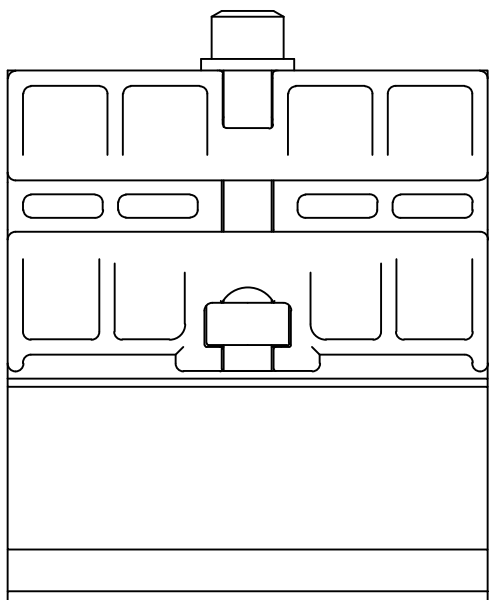

A

A

TOLERANCE X.X..... = ± .060 X.XX..... = ± .030 X.XXX..... = ± .010 XX°..... = ± 1° UNLESS OTHERWISE NOTED	CUT LENGTH:	FINISH:	DESCRIPTION: PanelGrip 2 for 1/2" Glass, Dry Mount Mechanism, w/ Brown Isolator and Red Pad	
		As Is	MATERIAL:	MATERIAL DESC:
	DEVELOPED LENGTH:	WEIGHT:	DATE:	REV:
		0.26 lbmass	3/18/2019	5
TOOL NUMBER:		DRAWN BY:	5	
		K. Bauserman	PG2460	
		PART NUMBER:	PG2460	



2



1

PANEL GRIP MECHANISM ASSEMBLY

PARTS LIST			
ITEM	QTY	PART NUMBER	DESCRIPTION
3	1	PGISO.090	Isolator HDPE White/PSA 3M 468MP One Side .090 Inch X 1.25 Inch X 2.5 Inch Printed
4	1	PG2T	PanelGrip, Zinc Aluminum, Cast, Top Block, .450" Thick, .57" High, 2.50" Long
5	1	PG2B	PanelGrip, Zinc Aluminum, Cast, Bottom Block, .450" Thick, .72" High, 2.50" Long
6	1	PG2C	PanelGrip, Zinc Aluminum, Cast, Center Block, .450" Thick, .76" High, 2.50" Long
7	1	PG2LW	Washer Lock, 1/4-20, Stainless Steel
8	1	PG2NUT	Nut, Stainless Steel, 1/4-20 FHN
9	1	SHC3N2520-0163	SCREW SS 1/4-20 X .50 SOCKET HEAD CAP

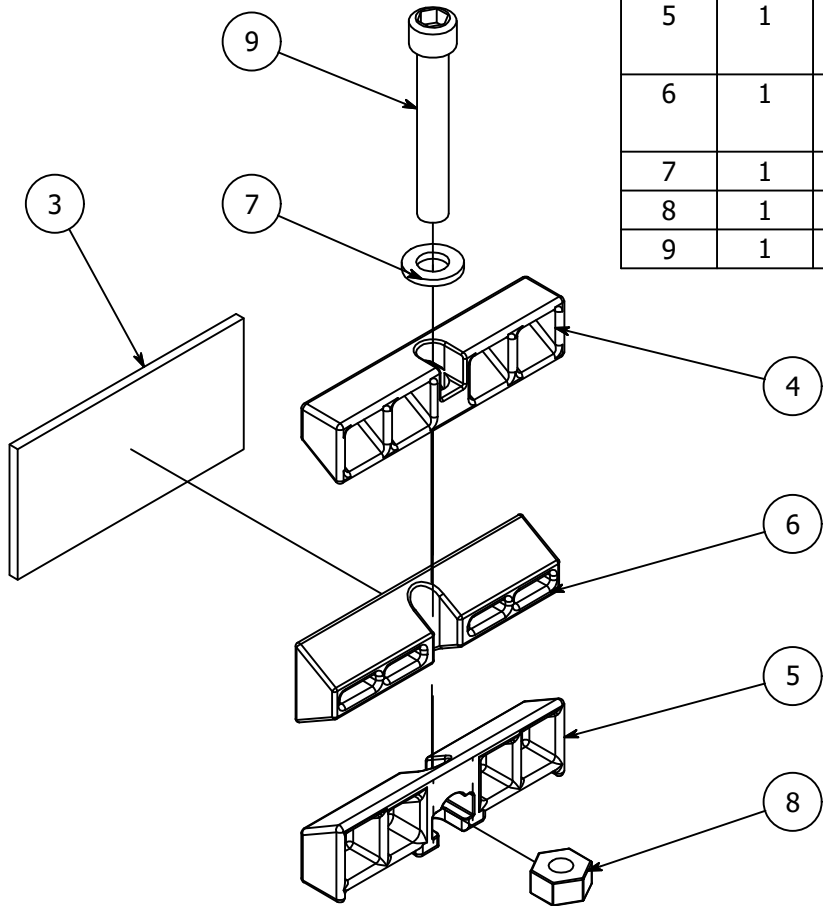

<p style="text-align: center;">TOLERANCE</p> <p>X.X..... = ± .060</p> <p>X.XX..... = ± .030</p> <p>X.XXX..... = ± .010</p> <p>XX°..... = ± 1°</p> <p>UNLESS OTHERWISE NOTED</p>	CUT LENGTH:	FINISH:	DESCRIPTION: PanelGrip 2 for 1/2" Glass, Dry Mount Mechanism, w/ Brown Isolator and Red Pad	
			As Is	MATERIAL:
	DEVELOPED LENGTH:	WEIGHT:	DATE:	MATERIAL DESC:
		0.26 lbmass	3/18/2019	REV:
TOOL NUMBER:			5	 WAGNER COLLABORATIVE METAL WORKS
		DRAWN BY: K. Bauserman		
		PART NUMBER: PG2460		

2



1

PARTS LIST

ITEM	QTY	PART NUMBER	DESCRIPTION
1	1	GR2460HCBMKR	Shoe Moulding, Al, Corner, PanelGrip, For 0.5" Glass
2	1	GR2460HCBMKL	Shoe Moulding, Al, Corner, PanelGrip, For 0.5" Glass

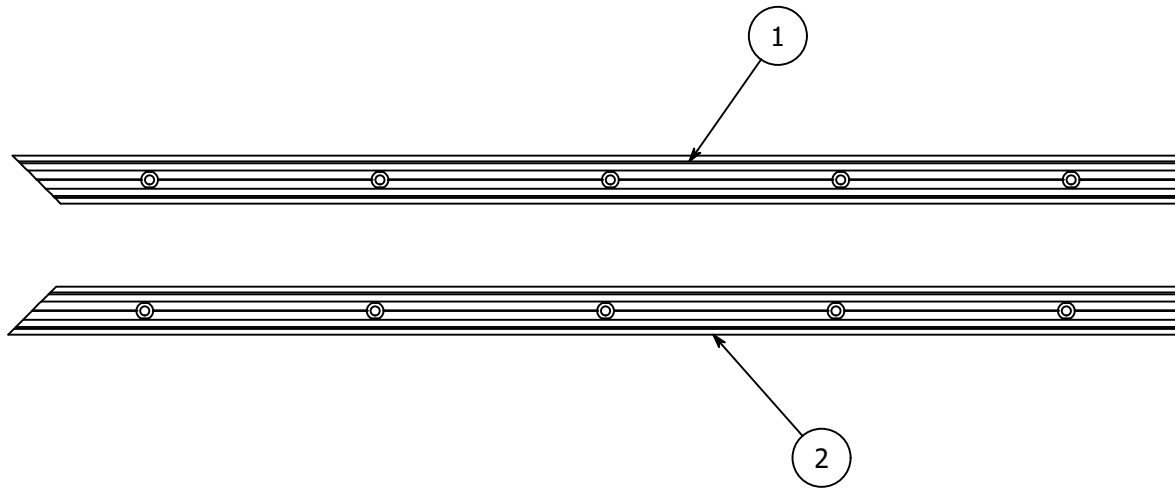
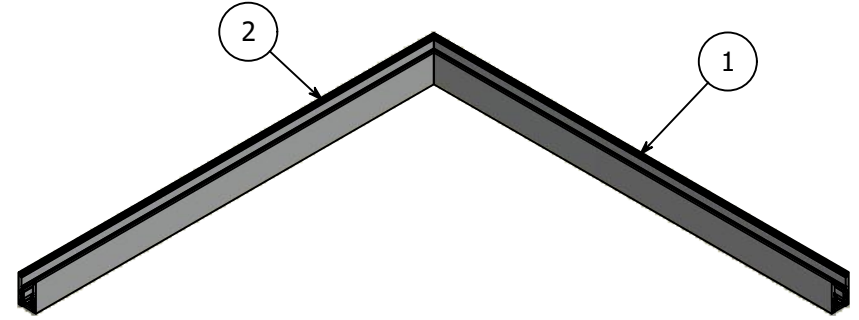

TOLERANCE UNLESS OTHERWISE NOTED, TOLERANCES TO CONFORM TO ES.03.011	MATERIAL: Aluminum	DESCRIPTION: Shoe Moulding, Aluminum, Corner, PanelGrip, For 0.5" Glass	
	FINISH: Mill	DATE: 6/10/2021	REV: 1
	WEIGHT: N/A	DRAWN BY: T. Haapakoski	
		ITEM NUMBER: GR2460HCBMK	 10600 W Brown Deer Rd Milwaukee, WI 53224 http://www.wagnercompanies.com/

2



1

B

B



A

A

2



1

B

B

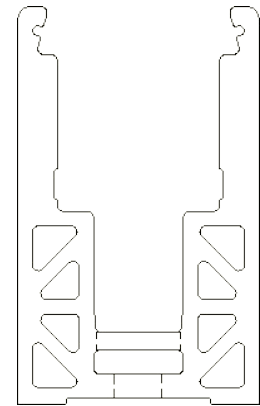
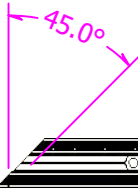

A

A

TOLERANCE UNLESS OTHERWISE NOTED, TOLERANCES TO CONFORM TO ES.03.011	CUT LENGTH:	5 Feet	FINISH:	Mill	DESCRIPTION: Shoe Moulding, Al, Corner, PanelGrip, For 0.5" Glass	
	DEVELOPED LENGTH:		WEIGHT:	N/A	MATERIAL:	Aluminum
	TOOL NUMBER:				MATERIAL DESC:	Aluminum 6005-T5
					DATE:	6/10/2021
					DRAWN BY:	T. Haapakoski
					REV:	-
					PART NUMBER:	GR2460HCBMKL



10600 W Brown Deer Rd
Milwaukee, WI 53224
COLLABORATIVE METALWORKS <http://www.wagnercompanies.com/>

2



1

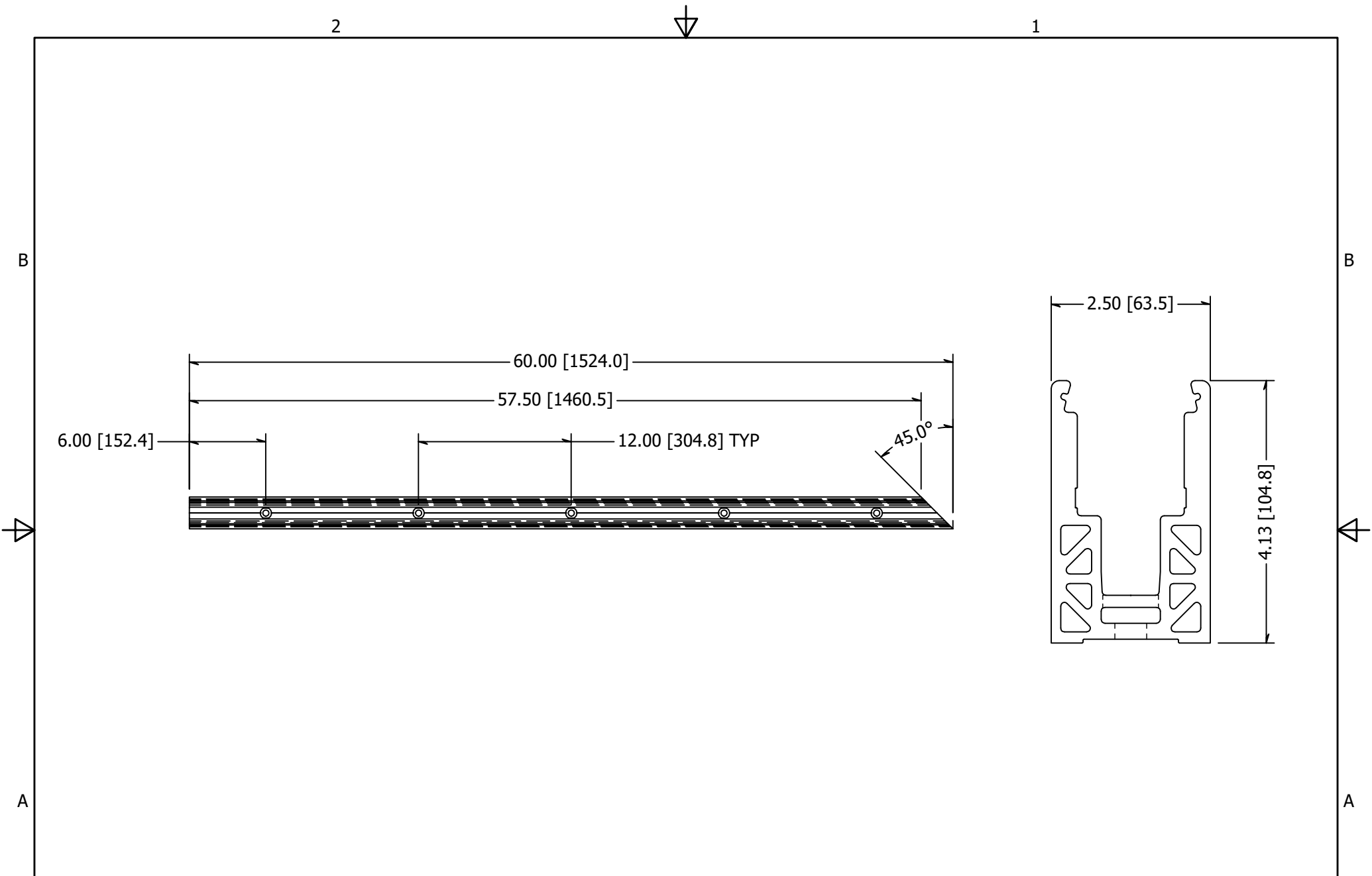

TOLERANCE UNLESS OTHERWISE NOTED, TOLERANCES TO CONFORM TO ES.03.011	CUT LENGTH:	FINISH:	DESCRIPTION:	
		Mill	Shoe Moulding, Al, Corner, PanelGrip, For 0.5" Glass	
	DEVELOPED LENGTH:	WEIGHT:	MATERIAL:	MATERIAL DESC:
		23.31 lbmass	Aluminum	
	TOOL NUMBER:		DATE:	REV:
			6/10/2021	-
			DRAWN BY:	
			T. Haapakoski	
			PART NUMBER:	
			GR2460HCBMKR	

WAGNER™ 10600 W Brown Deer Rd
Milwaukee, WI 53224
COLLABORATIVE METALWORKS <http://www.wagnercompanies.com/>

