

REV  
SH  
639T  
DWG NO

REVISIONS			
REV	DESCRIPTION	DATE	APPROVED

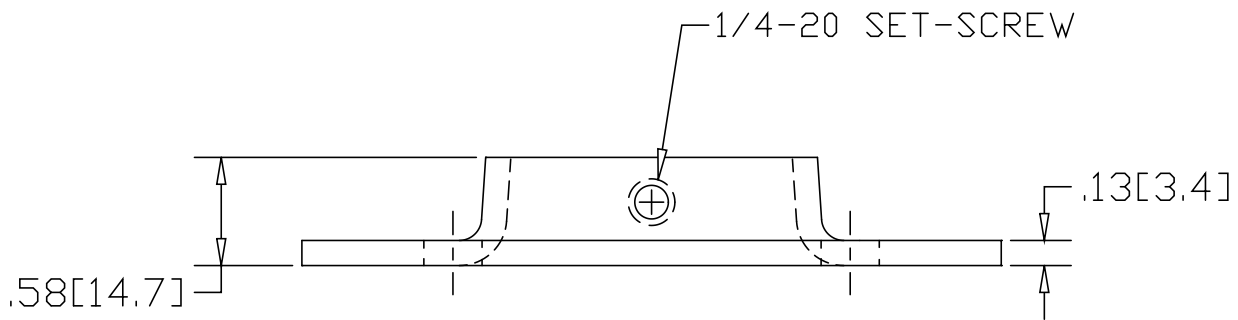
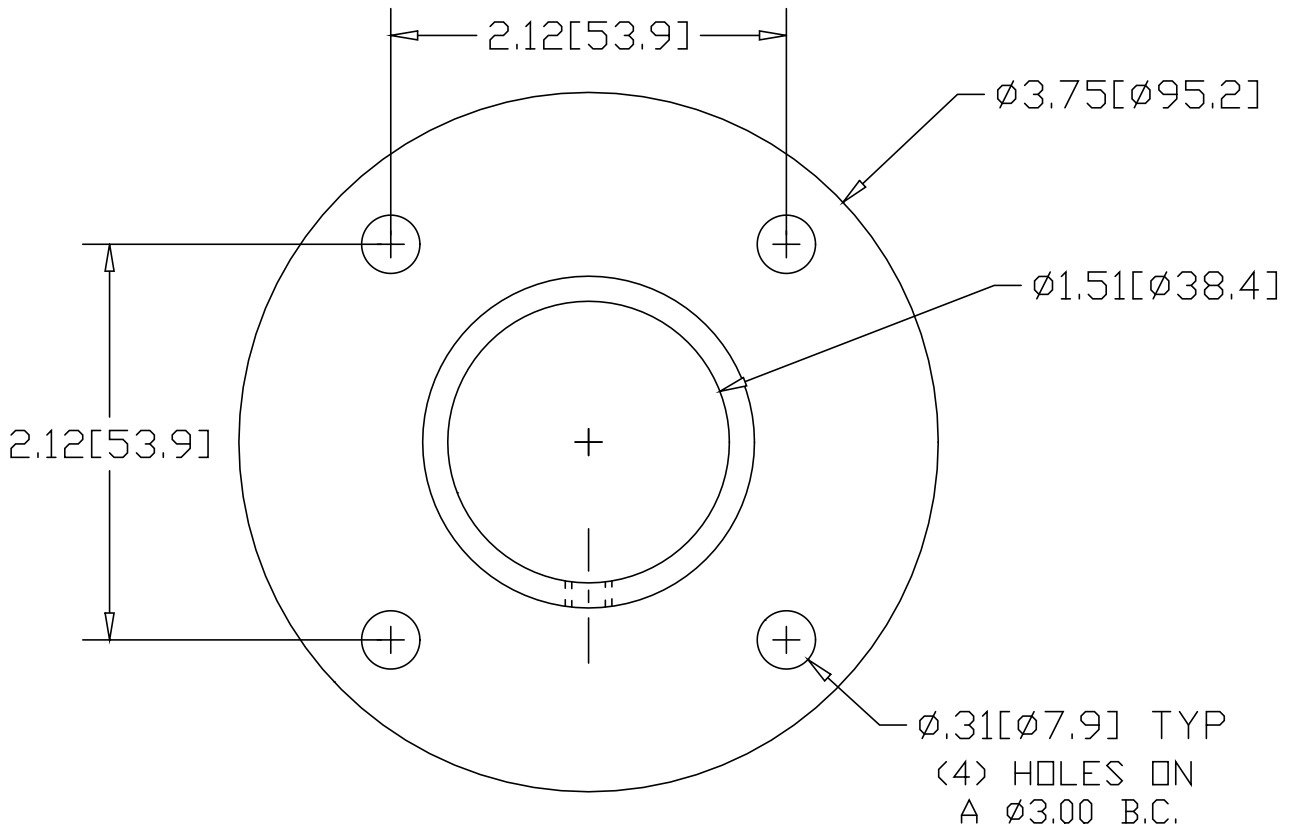

INCHES [MILLIMETERS]

ALTERNATE MATERIAL	PART NUMBER
.125 (3003) ALUMINUM ASTM B209	679T
10 GA. (304) STAINLESS STEEL ASTM A240	719T

PART NAME 1-1/2" O.D. TUBE FLAT BASE FLANGE W/(4) HOLES AND SET-SCREW			
MATERIAL 10 GA. HRP&O STEEL ASTM A-569			
DATE 1/11/99	<b>WAGNER</b>	R & B WAGNER, INC.	
DRAWN BY RJF			
FINISH MILL	SIZE A	WEIGHT .42 lbs	PART NUMBER 639T
			REV