

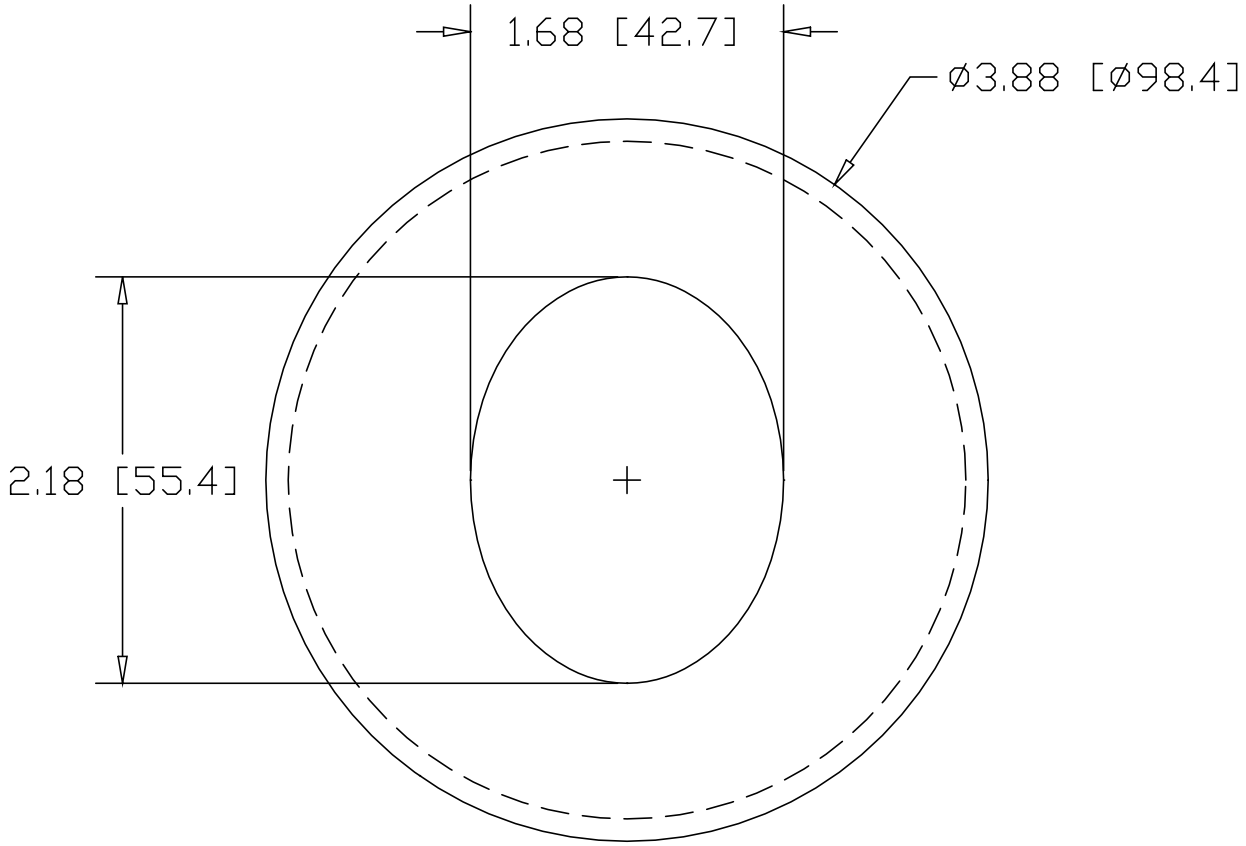

REV
SH
2826
DWG NO

REVISIONS			
REV	DESCRIPTION	DATE	APPROVED



INCHES [MILLIMETERS]

ALTERNATE MATERIAL	PART NUMBER
.125 (3003) ALUMINUM ASTM B209	2866
10 GA. (304) STAINLESS STEEL ASTM A240	2906

PART NAME 1-1/4" PIPE HEAVY FLUSH BASE BEVELED FLANGE			
MATERIAL 10 GA. HRP&D STEEL ASTM A569			
DATE 9/6/94		THE WAGNER COMPANIES R & B WAGNER, INC. AND J. G. BRAUN CO.	
DRAWN BY RJF			
FINISH MILL			
SIZE A	WEIGHT .5 LBS	PART NUMBER 2826	REV