

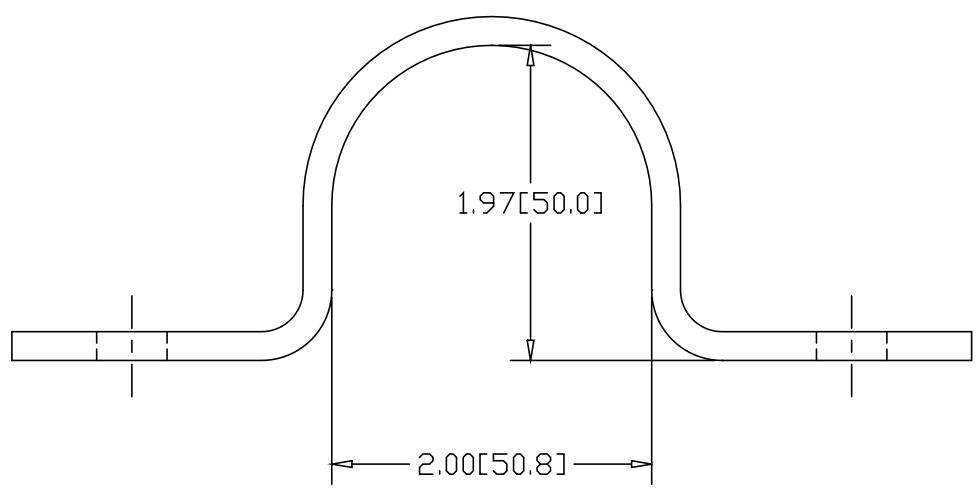

REV
SH
3723
DWG NO

REVISIONS			
REV	DESCRIPTION	DATE	APPROVED

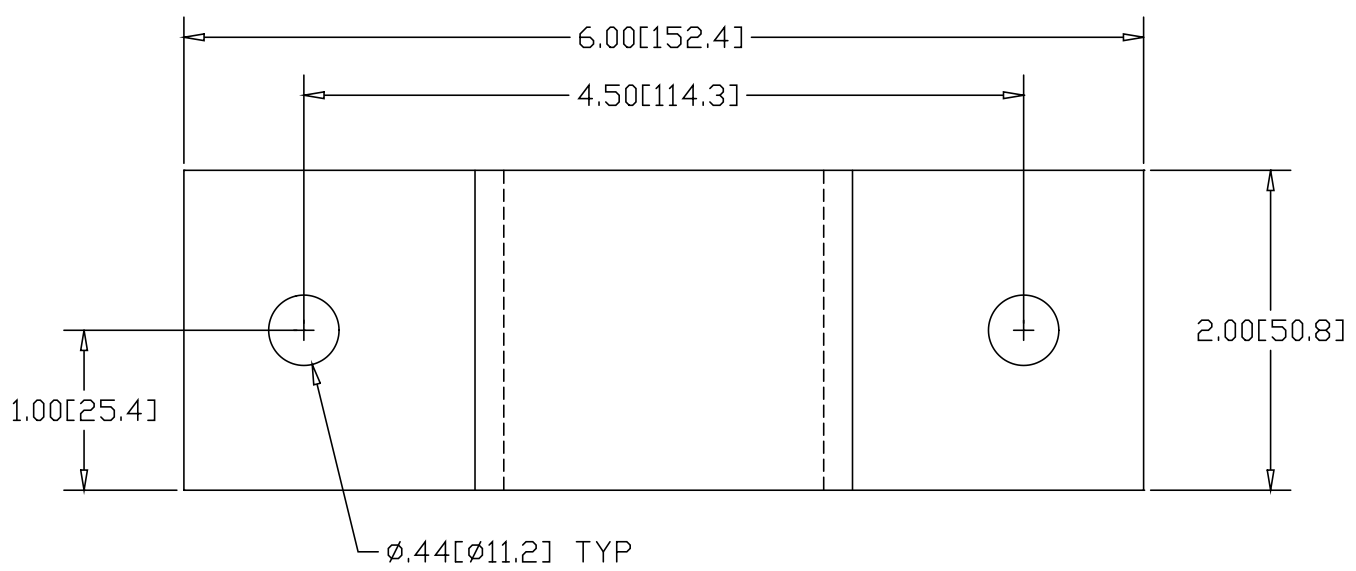

INCHES [MILLIMETERS]

ALTERNATE MATERIAL	PART NUMBER
.190 (3003) ALUMINUM ASTM B209	3723A
7 GA. (304) STAINLESS STEEL ASTM A240	3723-SS

PART NAME 2.00" OD X 2" WIDE U-BRACKET W/(2) HOLES				
MATERIAL 7 GA. HRP&D STEEL ASTM A569				
DATE 1/13/00	 THE WAGNER COMPANIES R & B WAGNER, INC. AND J. G. BRAUN CO.			
DRAWN BY RJF		SIZE A	WEIGHT .78 LBS	PART NUMBER 3723
FINISH MILL				REV