

REV

SH

1414AT

DWG NO

REVISIONS

REV	DESCRIPTION	DATE	APPROVED

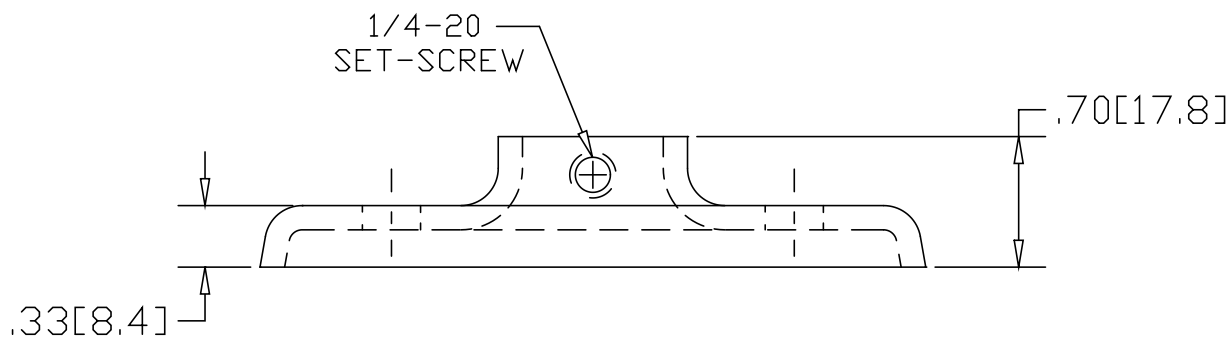
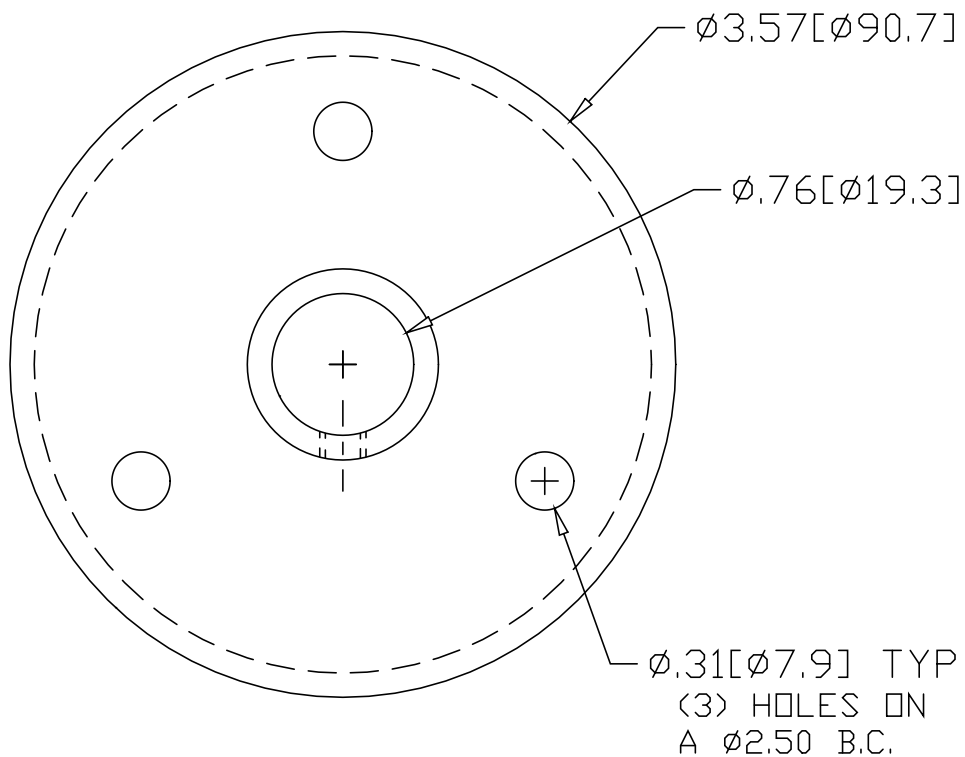

INCHES [MILLIMETERS]

ALTERNATE MATERIAL	PART NUMBER
.125 (3003) ALUMINUM ASTM B209	1454AT
10 GA. (304) STAINLESS STEEL ASTM A240	1514AT

PART NAME .75" OD TUBE HEAVY BASE FLANGE W/(3) HOLES & SET-SCREW

MATERIAL 10 GA. HRP&D STEEL ASTM A569

DATE 9/13/94

DRAWN BY RJF

FINISH

MILL

R & B WAGNER, INC.

SIZE	WEIGHT
A	.41 LBS

PART NUMBER

1414AT

REV