

REV
SH
1665
DWG NO

REVISIONS			
REV	DESCRIPTION	DATE	APPROVED

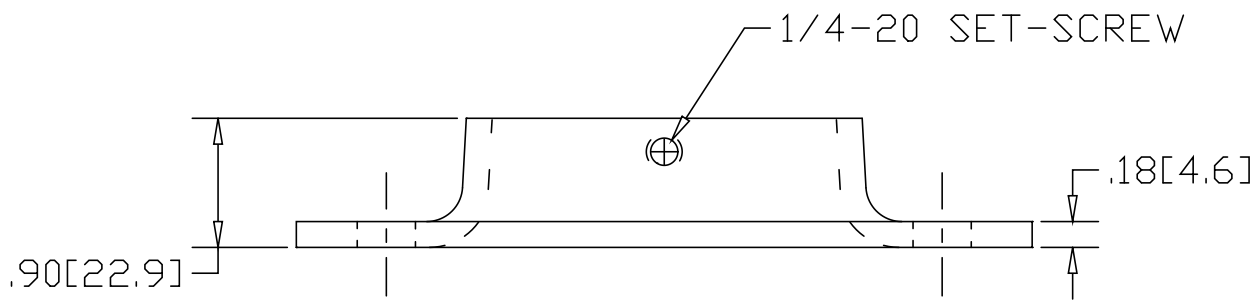
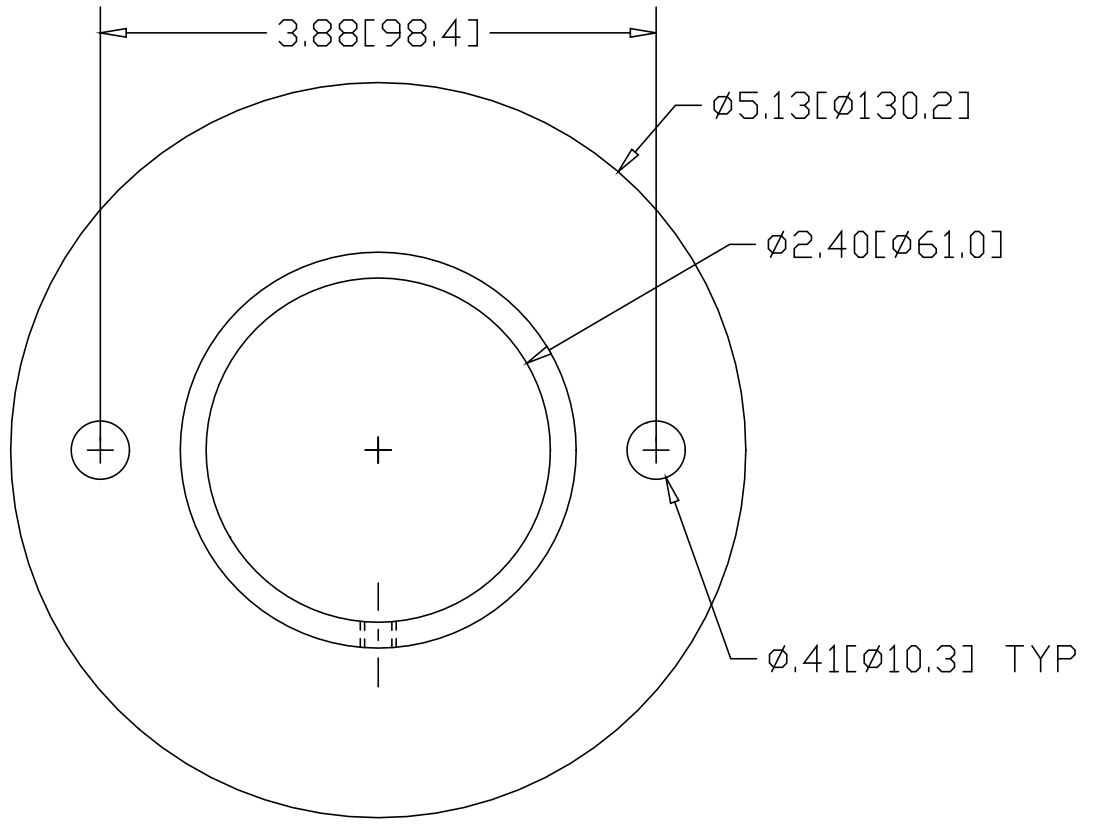

INCHES [MILLIMETERS]

ALTERNATE MATERIAL	PART NUMBER
.19 (3003) ALUMINUM ASTM B-209	1675

PART NAME 2" PIPE SIZE EXTRA HEAVY FLANGE W/(2) HOLES & SET-SCREW				
MATERIAL 7 GA. HRP&D STEEL ASTM A-569				
DATE 3/2/95				
DRAWN BY RJF				
FINISH MILL	SIZE A	WEIGHT .94 LBS	PART NUMBER 1665	REV