

REVISIONS			
REV	DESCRIPTION	DATE	APPROVED

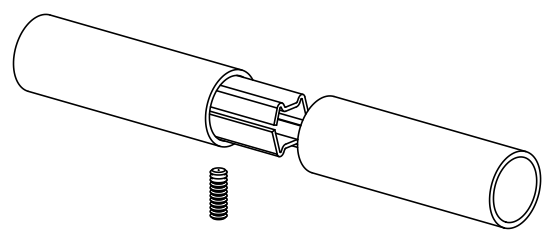

2" SCHEDULE 40 PIPE
(2.38 O.D. X .154 WALL)

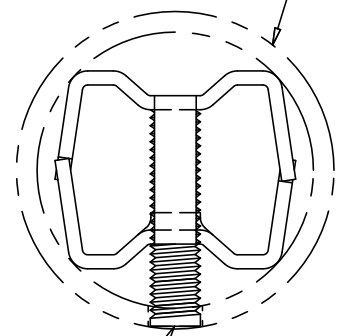
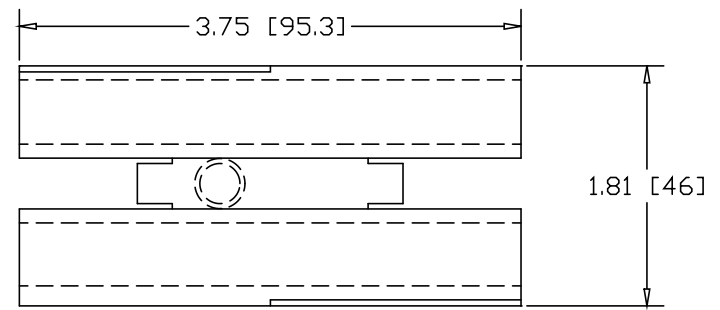

3/8-16 SOCKET HEAD
SET-SCREW X 1-5/8" LONG

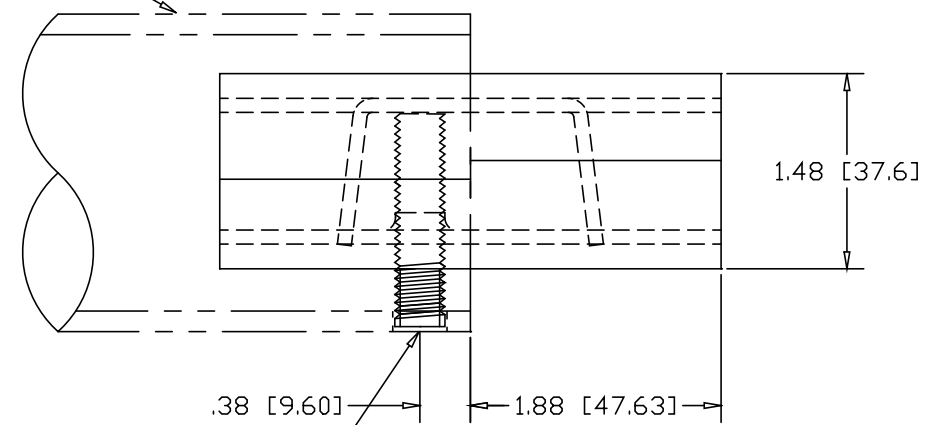

DRILL ϕ .406 HOLE
.38" IN FROM END

INCHES [MILLIMETERS]

ALTERNATE MATERIAL	PART NO.
12 GA. STEEL HOT DIP GALVANIZED	G3322
12 GA. STEEL ZINC PLATED	PL3322
.090 (3003) ALUMINUM ASTM B209	3323
.090 (304) STAINLESS STEEL ASTM A240	3325

PART NAME		2" SCH40 PIPE SINGLE-LOCK SPLICE-LOCK		
MATERIAL		12 GA. HRP&D STEEL ASTM A569		
DATE	5/10/96	 THE WAGNER COMPANIES R & B WAGNER, INC. AND J. G. BRAUN CO.	PART NUMBER	3322
DRAWN BY	RJF			
FINISH	MILL			
SIZE	A	WEIGHT	.62 LBS	REV