

REV  
SH  
1420  
DWG NO

REVISIONS			
REV	DESCRIPTION	DATE	APPROVED

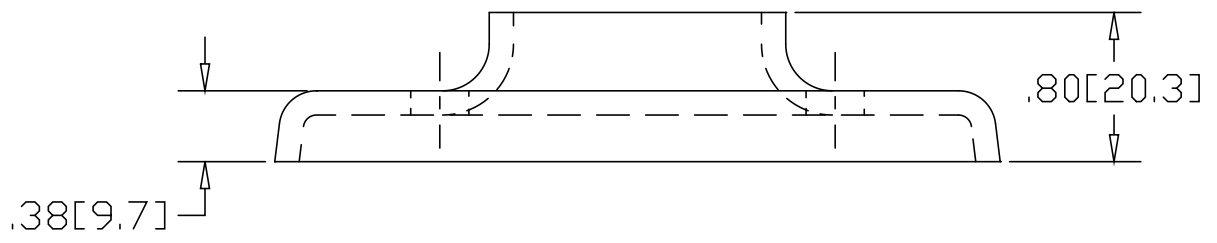
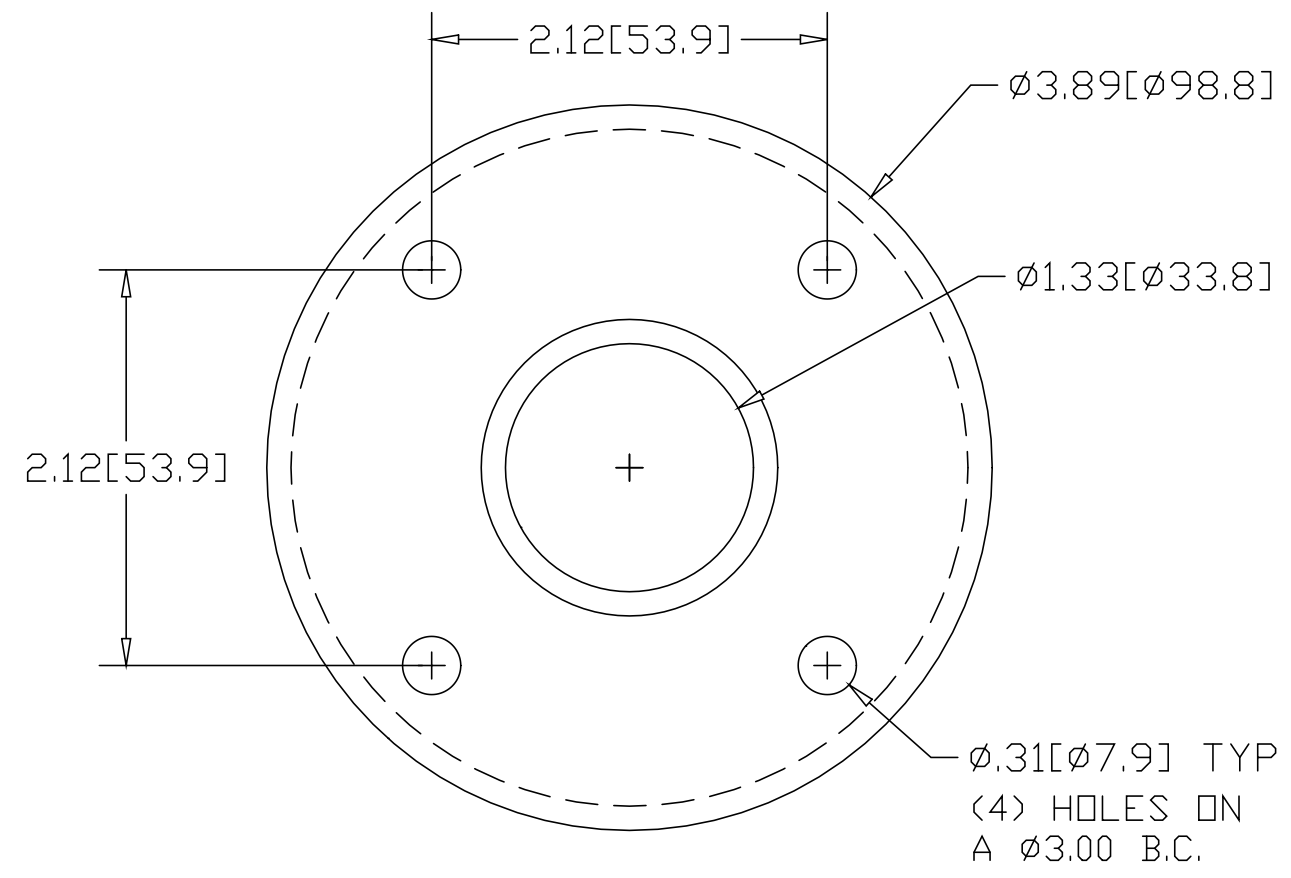

\*USE WITH ANCHOR PLATE  
 #B1432 IN STEEL  
 #PLB1432 ZINC PLATED STEEL  
 #B1532 IN STAINLESS STEEL

INCHES [MILLIMETERS]

ALTERNATE MATERIAL	PART NUMBER
.125 (3003) ALUMINUM ASTM B209	1460
10 GA. (304) STAINLESS STEEL ASTM A240	1520

PART NAME 1" PIPE HEAVY BASE FLANGE W/(4) HOLES			
MATERIAL 10 GA. HRP&D STEEL ASTM A569			
DATE 9/13/94	 <b>R &amp; B WAGNER, INC.</b>		
DRAWN BY RJF			
FINISH MILL			
SIZE A	WEIGHT .50 LBS	PART NUMBER 1420	REV