

PARTS LIST

ITEM	QTY	PART NUMBER	DESCRIPTION
1	1	LG32242ESMA	End Post, Stainless Steel, 2.00 Inch Square x 0.12 Inch Wall, 42 High, Brushed Satin Finish, Grade 316, Surface Mount, Assm
2	1	LG322SMC	Flange, Stainless Steel, Snap-On Cover For 2 Inch Square Tube, Satin Brushed Finish, Type 316
3	1	SS507	SADDLE, SWIVEL, CAST W/ HOLES
4	2	LXTB51-1	Point Fitting, Stainless Steel, 51 mm Head, 1 Point, Tubular Body, Brushed Satin Finish, Grade 316, 0.50 Inch Glass

B

B

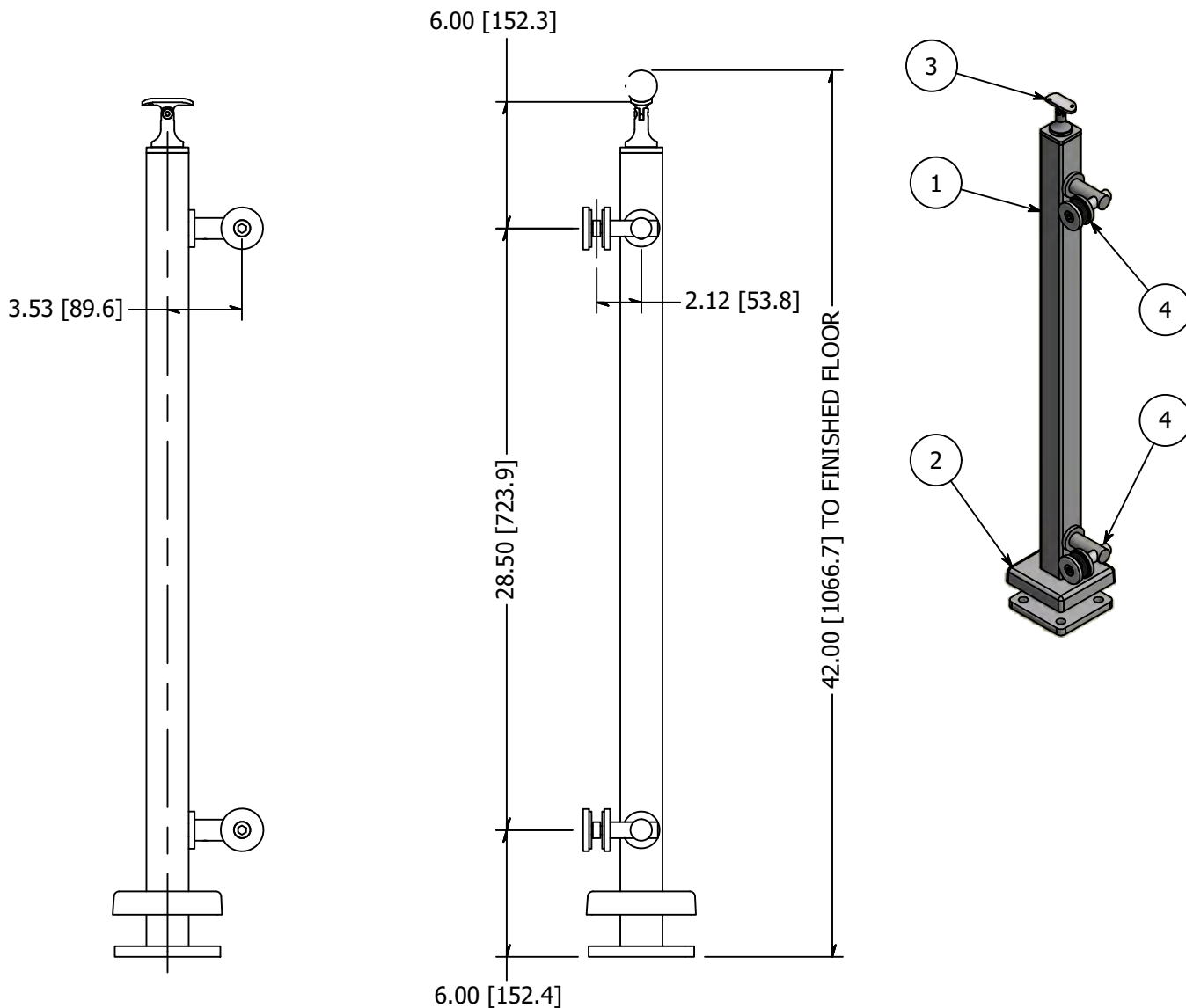

A

A

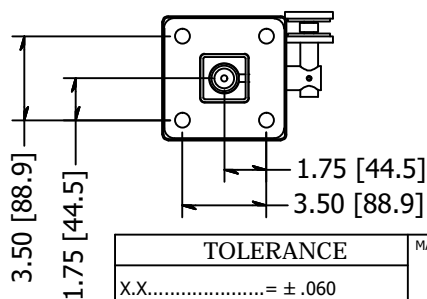

REVISION HISTORY			
REV	DESCRIPTION	DATE	APPROVED
1	Revised to metric	3/24/15	TLK
2	Revised LXTB51-1 to LX51FBS	10/27/15	KGB
3	Revised LX51FBS to LXTB51-1	8/24/2016	TLK
4	Wall Thickness was changed from 0.25 to 0.12 and the corner radii from .375 to .188 on the square post	3/13/2019	ATM

TOLERANCE
X.X..... = ± .060
X.XX..... = ± .030
X.XXX..... = ± .010
XX°..... = ± 1°
UNLESS OTHERWISE NOTED

MATERIAL: 316 Stainless	DESCRIPTION: End Post, Stainless Steel, 2.00 Inch Square x 0.12 Inch Wall, 42 High, Brushed Satin Finish, Grade 316, Surface Mount, 2-Point	
FINISH: Satin Brushed	DATE: 8/19/2019	REV: 4
WEIGHT: N/A	DRAWN BY: T. Kolbach	
ITEM NUMBER: LG32242CESM.4		

