

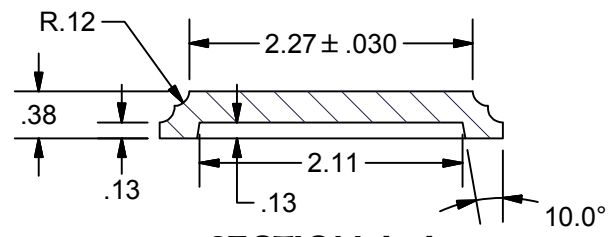

REVISION HISTORY

REV	DESCRIPTION	DATE	APPROVED
3	REPLACED MODEL	04/06/16	RJF

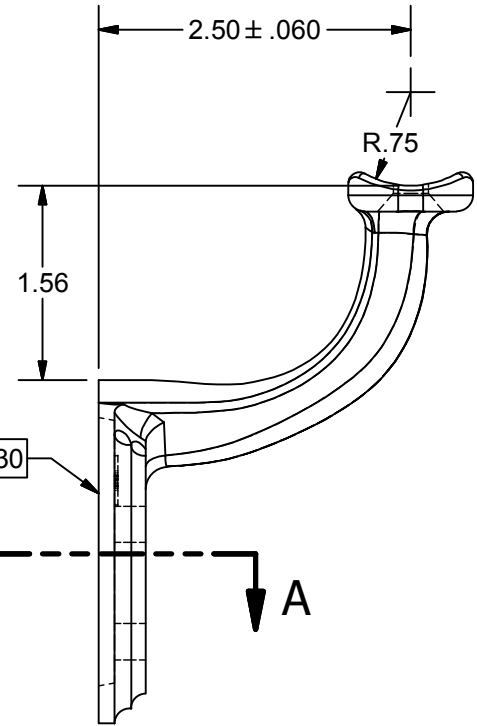
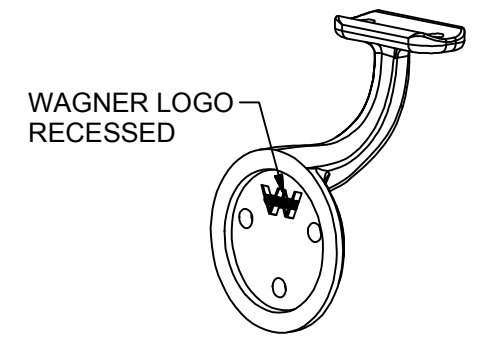
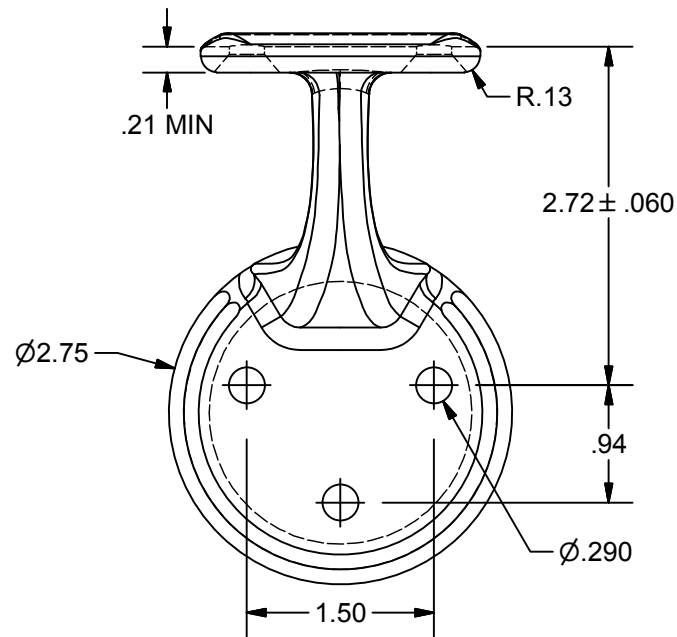
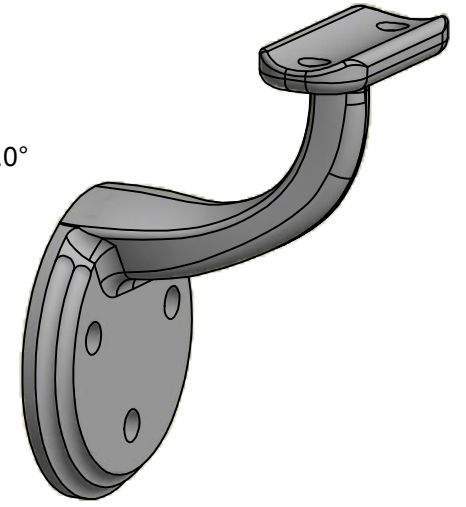
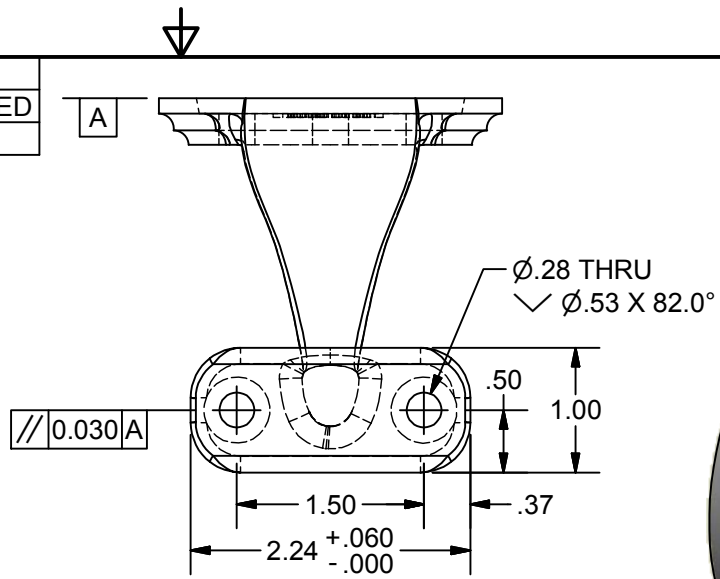

SECTION A-A

NAME		2.50" TRADITIONAL CAST HANDRAIL BRACKET					
MATERIAL		DUCTILE IRON ASTM A536 65-45-12					
DATE	11/12/2015	COLLABORATIVE METAL WORKS					
DRAWN	RJF	 WAGNER ™					
FINISH	MILL						
SIZE	A	WEIGHT	.769 LBS	PART NUMBER	1766-3	REV	3