

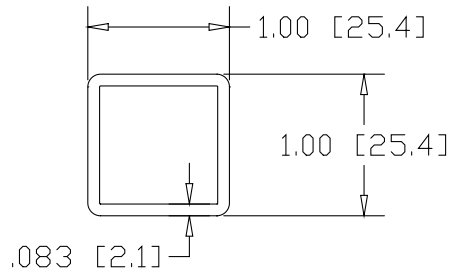

REV
SH
6308
DWG NO

REVISIONS			
REV	DESCRIPTION	DATE	APPROVED

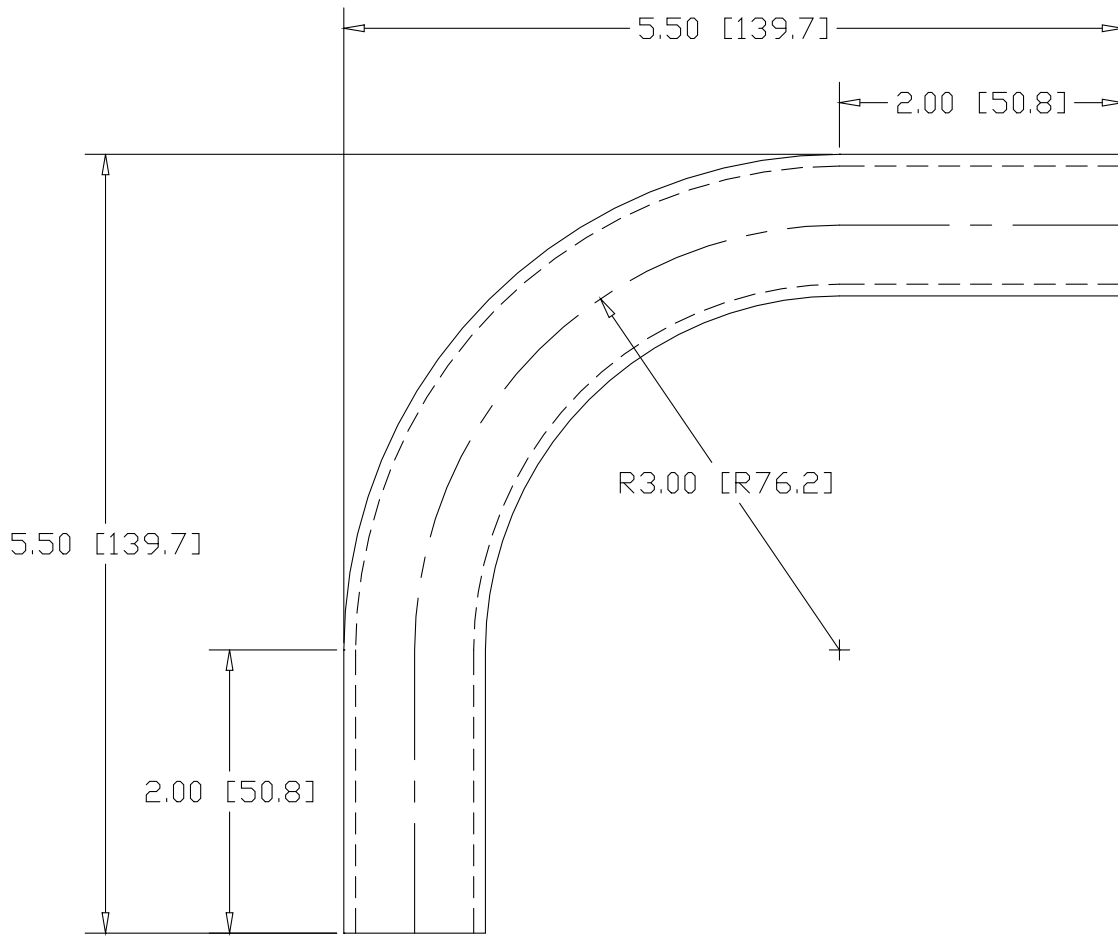

INCHES [MILLIMETERS]

ALTERNATE MATERIAL	PART NUMBER
1.00" SQUARE X .125W (6063) ALUMINUM TUBE	6408

PART NAME 1" SQUARE STEEL 90° X 3"CLR ELL W/(2) 2" TANGENTS			
MATERIAL 1.00" X .083W SQUARE STEEL TUBE			
DATE 10/3/00		R & B WAGNER, INC.	
DRAWN BY RJF		SIZE A	WEIGHT .76 LBS
FINISH MILL			REV