

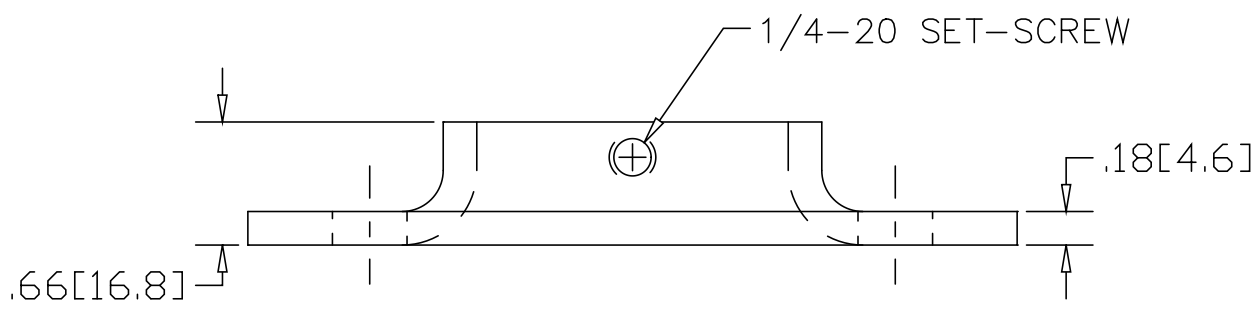

REV
SH
1616
DWG NO

REVISIONS			
REV	DESCRIPTION	DATE	APPROVED

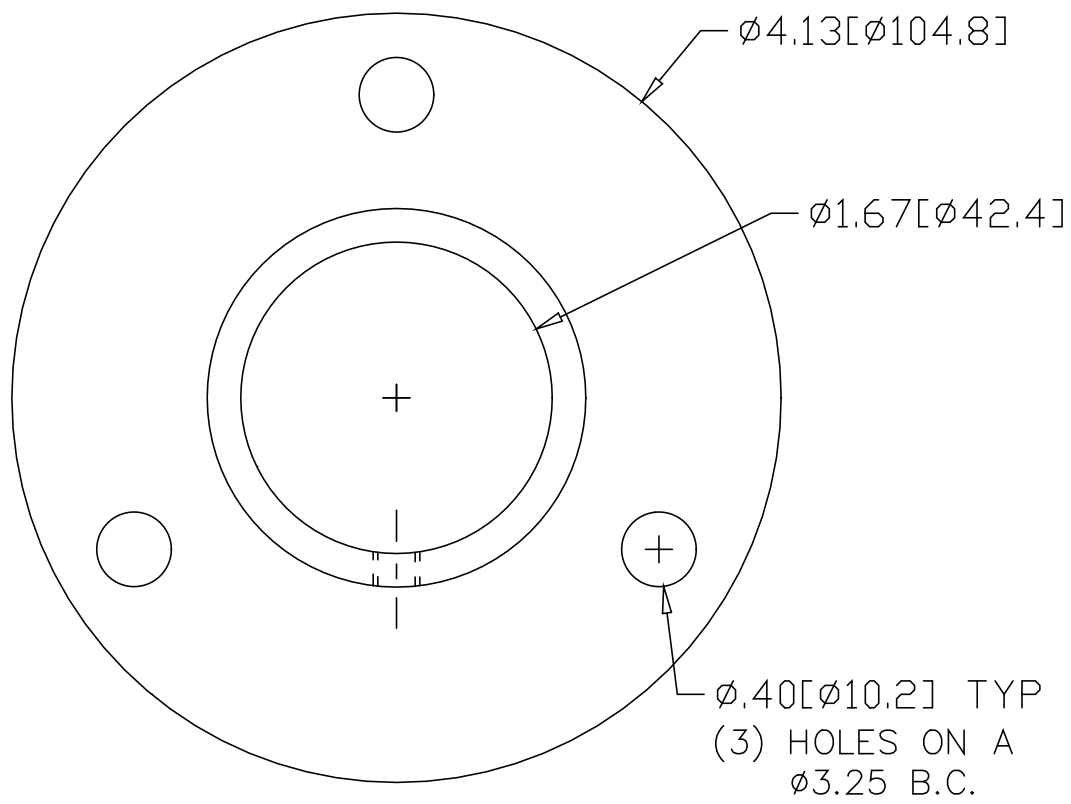

INCHES [MILLIMETERS]

ALTERNATE MATERIAL	PART NUMBER
3/16" (3003) ALUMINUM ASTM B-209	1636

PART NAME 1-1/4" PIPE SIZE EXTRA HEAVY FLANGE W/(3) HOLES AND SET-SCREW				
MATERIAL 3/16" HRP&O STEEL ASTM A-569				
DATE 1/15/95	 R & B WAGNER, INC.			
DRAWN BY RJF				
FINISH MILL	SIZE A	WEIGHT .6 LBS	PART NUMBER 1616	REV