

REV

SH

615T

DWG NO

## REVISIONS

REV	DESCRIPTION	DATE	APPROVED

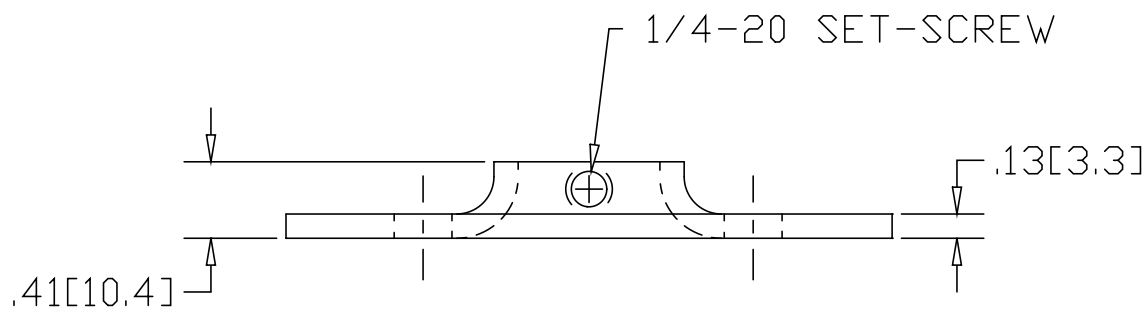
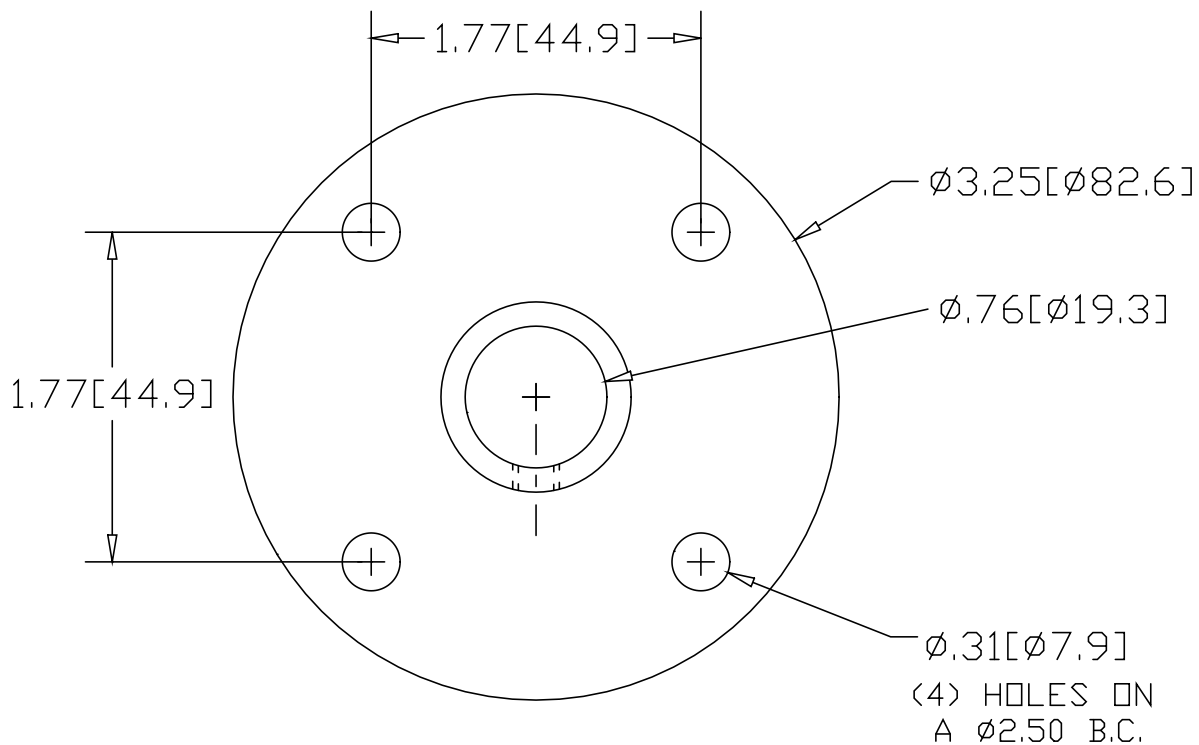

INCHES [MILLIMETERS]

ALTERNATE MATERIAL	PART NUMBER
.125 (3003) ALUMINUM ASTM B209	655T
10 GA. (304) STAINLESS STEEL ASTM A240	695T

PART NAME .75" O.D. TUBE FLAT BASE FLANGE W/(4) HOLES AND SET-SCREW

MATERIAL 10 GA. HRP&amp;D STEEL ASTM A-569

DATE 1/8/99

DRAWN BY RJF

FINISH

MILL



R &amp; B WAGNER, INC.

SIZE WEIGHT

A

.3 LBS

PART NUMBER

615T

REV