

REVISIONS			
REV	DESCRIPTION	DATE	APPROVED

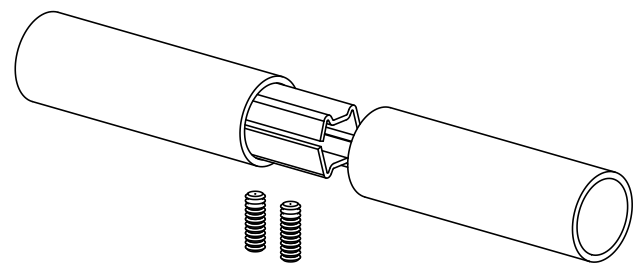

2" SCHEDULE 40 PIPE
(2.38 O.D. X .154 WALL)

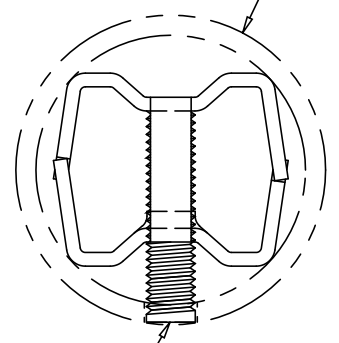
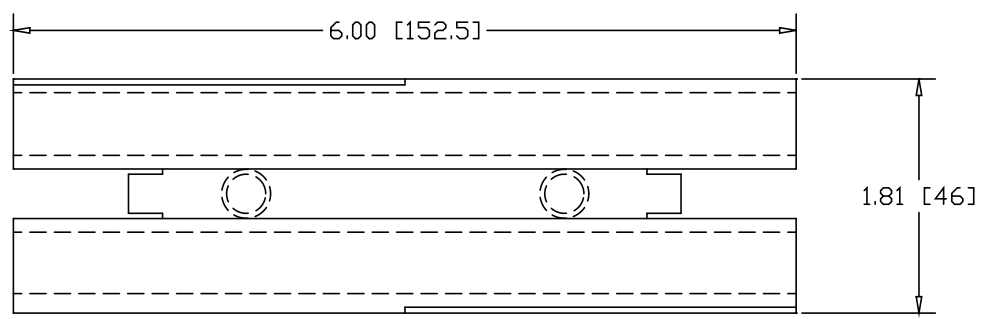

3/8-16 SOCKET HEAD
SET-SCREW X 1-5/8" LONG

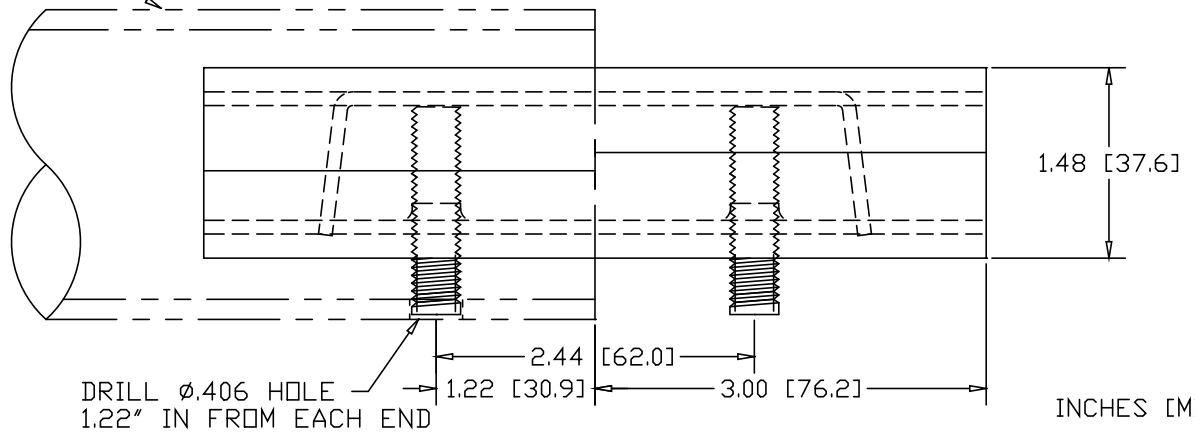

INCHES [MILLIMETERS]

ALTERNATE MATERIAL	PART NO.
12 GA. STEEL HOT DIP GALVANIZED	G3373
12 GA. STEEL ZINC PLATED	PL3373
.090 (3003) ALUMINUM ASTM B209	3377
.090 (304) STAINLESS STEEL ASTM A240	3377-2

PART NAME		2" SCH40 PIPE DOUBLE-LOCK SPLICE-LOCK 6" LONG					
MATERIAL		12 GAUGE HRP&D STEEL ASTM A569					
DATE	9/25/97	 R & B WAGNER, INC.					
DRAWN BY	RJF						
FINISH	MILL						
SIZE	A	WEIGHT	1.03 LBS	PART NUMBER	3373	REV	