

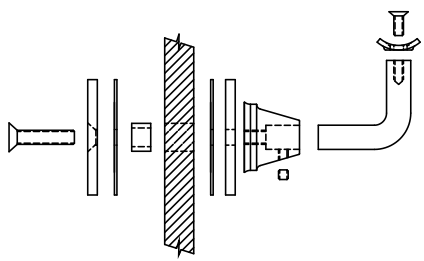

REVISIONS			
REV	DESCRIPTION	DATE	APPROVED
A	2.21 WAS 2.12	8/27/02	RJF
B	REVISED SADDLE	1/20/06	RDC

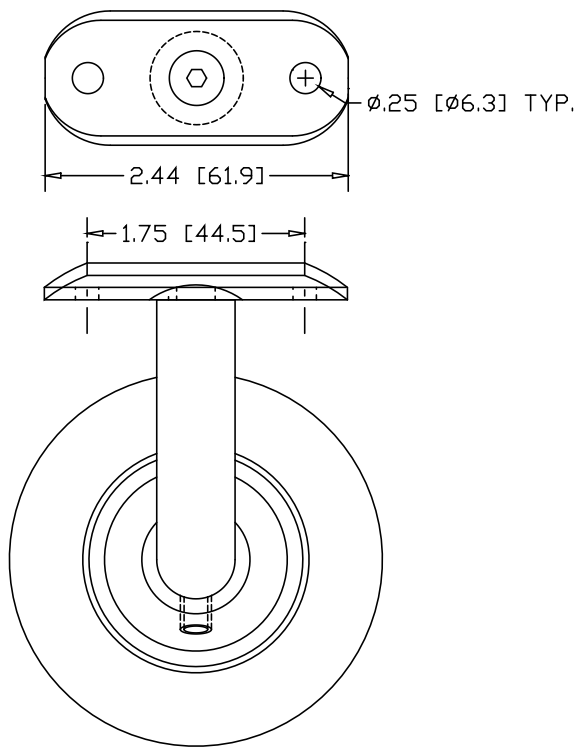
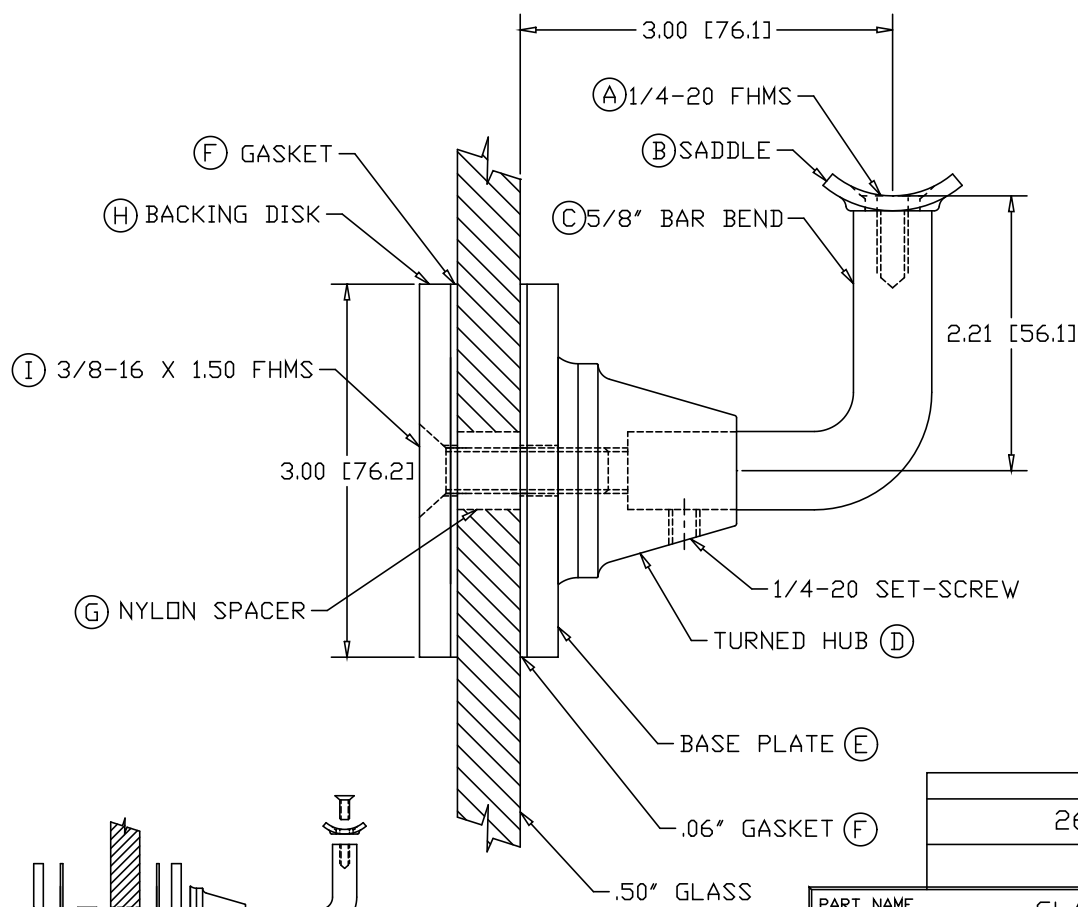

EXPLODED VIEW

ALTERNATE MATERIAL	PART NO.
260 BRASS	GB4385

PART NAME		GLASS BRACKET ASSEMBLY WITH BACKING DISK		
MATERIAL		6063 ALUMINUM		
DATE	7/21/98	 THE WAGNER COMPANIES R & B WAGNER, INC. AND J. G. BRAUN CO.		
DRAWN BY	RJF			
FINISH	#4 SATIN	SIZE	WEIGHT	PART NUMBER
		A	.68 LBS	GB4381
				REV B