

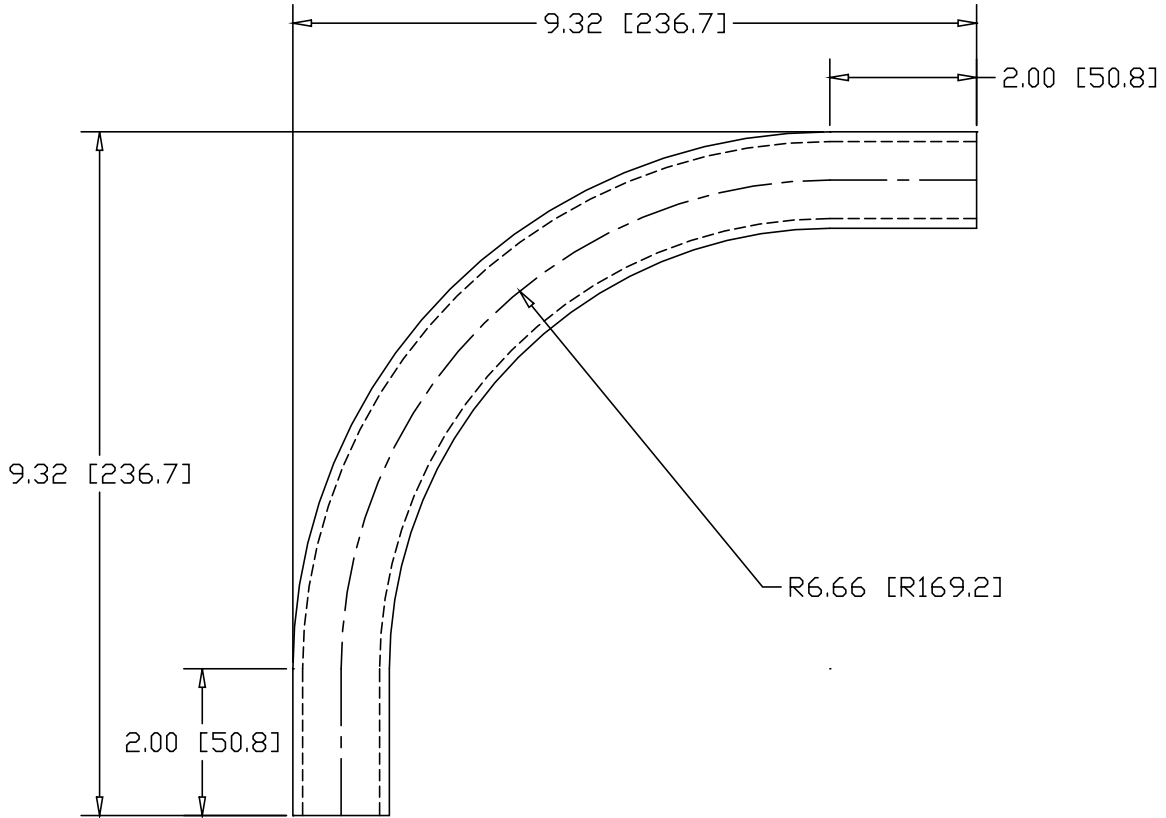

REV
SH
7409
DWG NO

REVISIONS			
REV	DESCRIPTION	DATE	APPROVED



INCHES [MILLIMETERS]

ALTERNATE MATERIAL	PART NUMBER
1" SCH 40 (6063) ALUMINUM PIPE	7429
1" SCH 40 (304) STAINLESS STEEL PIPE	7449

PART NAME 1" PIPE SIZE 90° ELL X 6" I.R. W/ (2) 2" TANGENTS			
MATERIAL 1" SCH 40 A53 STEEL PIPE			
DATE 7/5/01	 R & B WAGNER, INC.		
DRAWN BY JAH			
FINISH MILL			
SIZE A	WEIGHT 2.03 LBS	PART NUMBER 7409	REV