

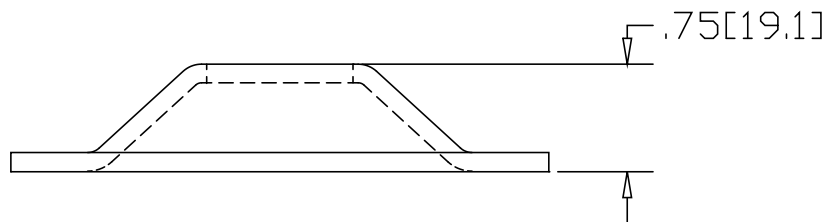

REV  
SH  
8041-NH  
DWG NO

REVISIONS			
REV	DESCRIPTION	DATE	APPROVED

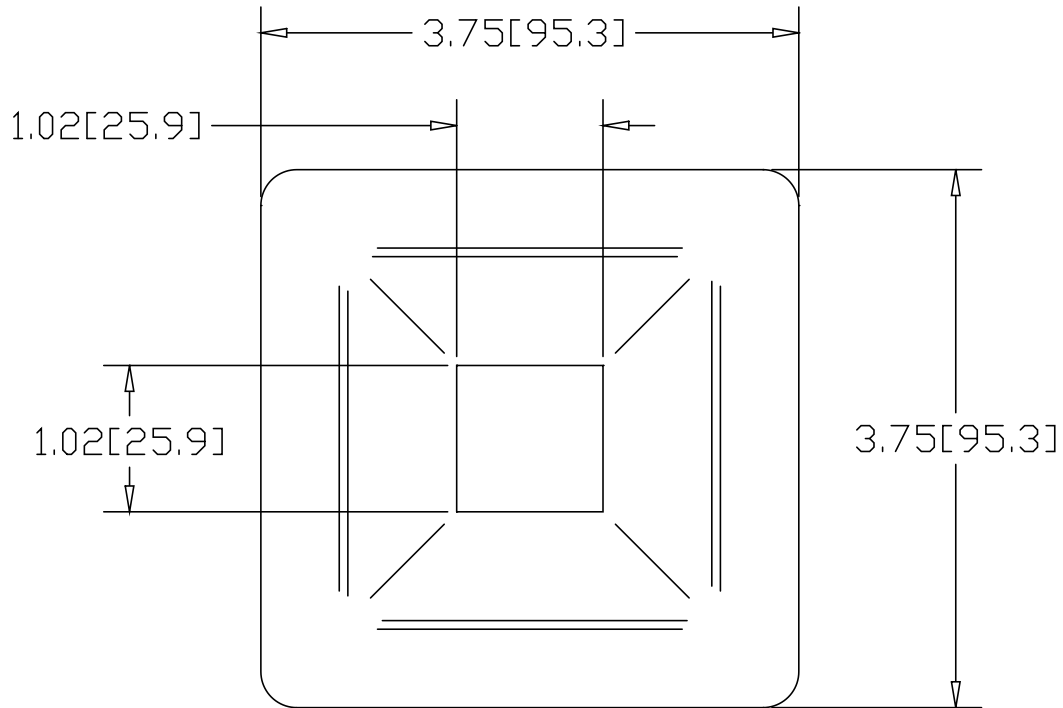

INCHES [MILLIMETERS]

ALTERNATE MATERIAL	PART NUMBER
.125 (3003) ALUMINUM ASTM B209	8042-NH

PART NAME		1" SQUARE TUBE FLANGE	
MATERIAL		10 GA. HRP&D STEEL ASTM A569	
DATE	7/24/96	 <b>R &amp; B WAGNER, INC.</b>	
DRAWN BY	RJF		
FINISH	MILL	SIZE	WEIGHT
		A	.53 LBS
		PART NUMBER	8041-NH
		REV	