

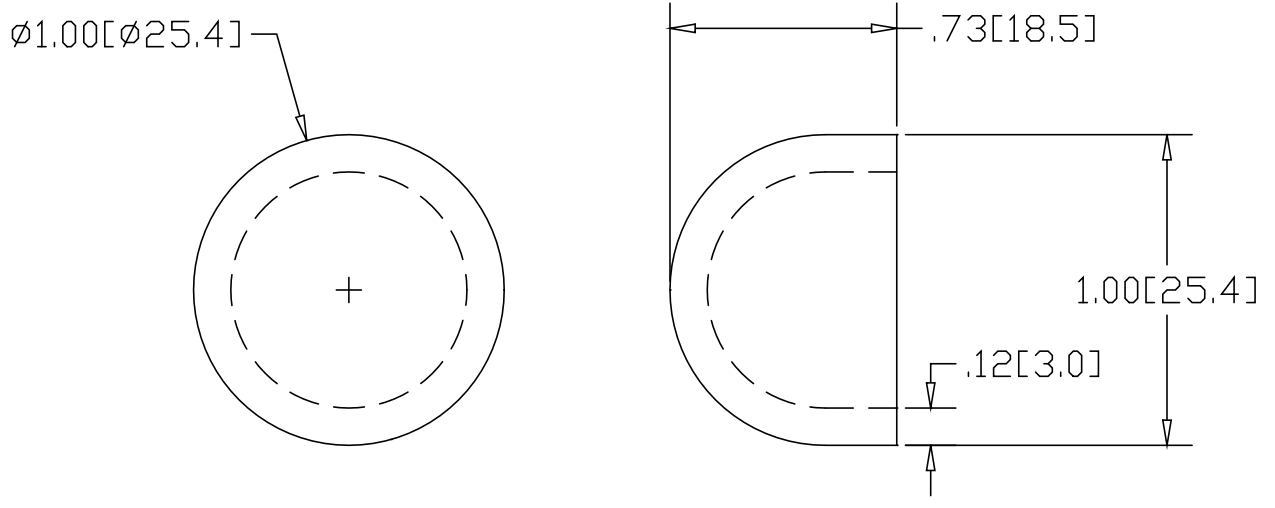

DWG NO 3233-1
SH
REV

REVISIONS			
REV	DESCRIPTION	DATE	APPROVED

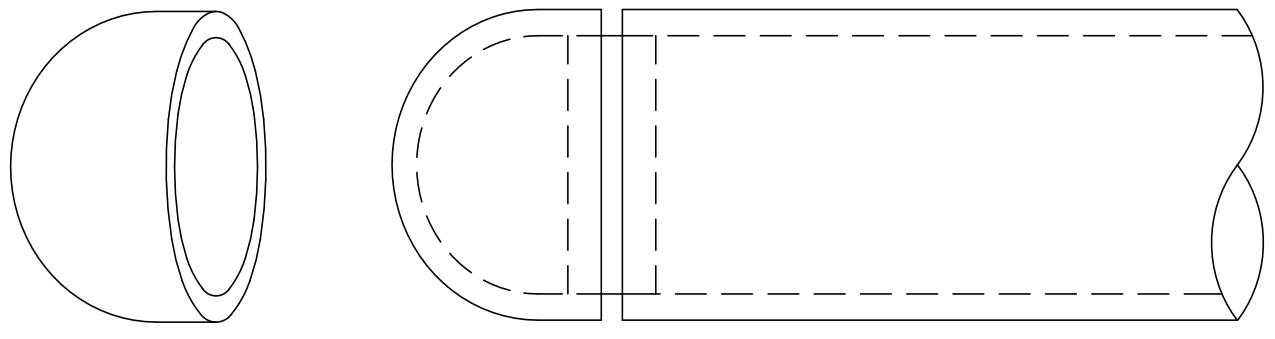

INCHES [MILLIMETERS]

ALTERNATE MATERIAL	PART NUMBER
.125 (3003) ALUMINUM ASTM B209	3234-1
11 GA. (304) STAINLESS STEEL ASTM A240	3263-1

PART NAME 1.00" OD TUBE TYPE "C" WELD-ON END CAP			
MATERIAL 11 GA. HRP&D STEEL ASTM A569			
DATE 6/13/96	 THE WAGNER COMPANIES R & B WAGNER, INC. AND J. G. BRAUN CO.		
DRAWN BY RJF			
FINISH MILL		SIZE A	WEIGHT .05 LBS
			REV