

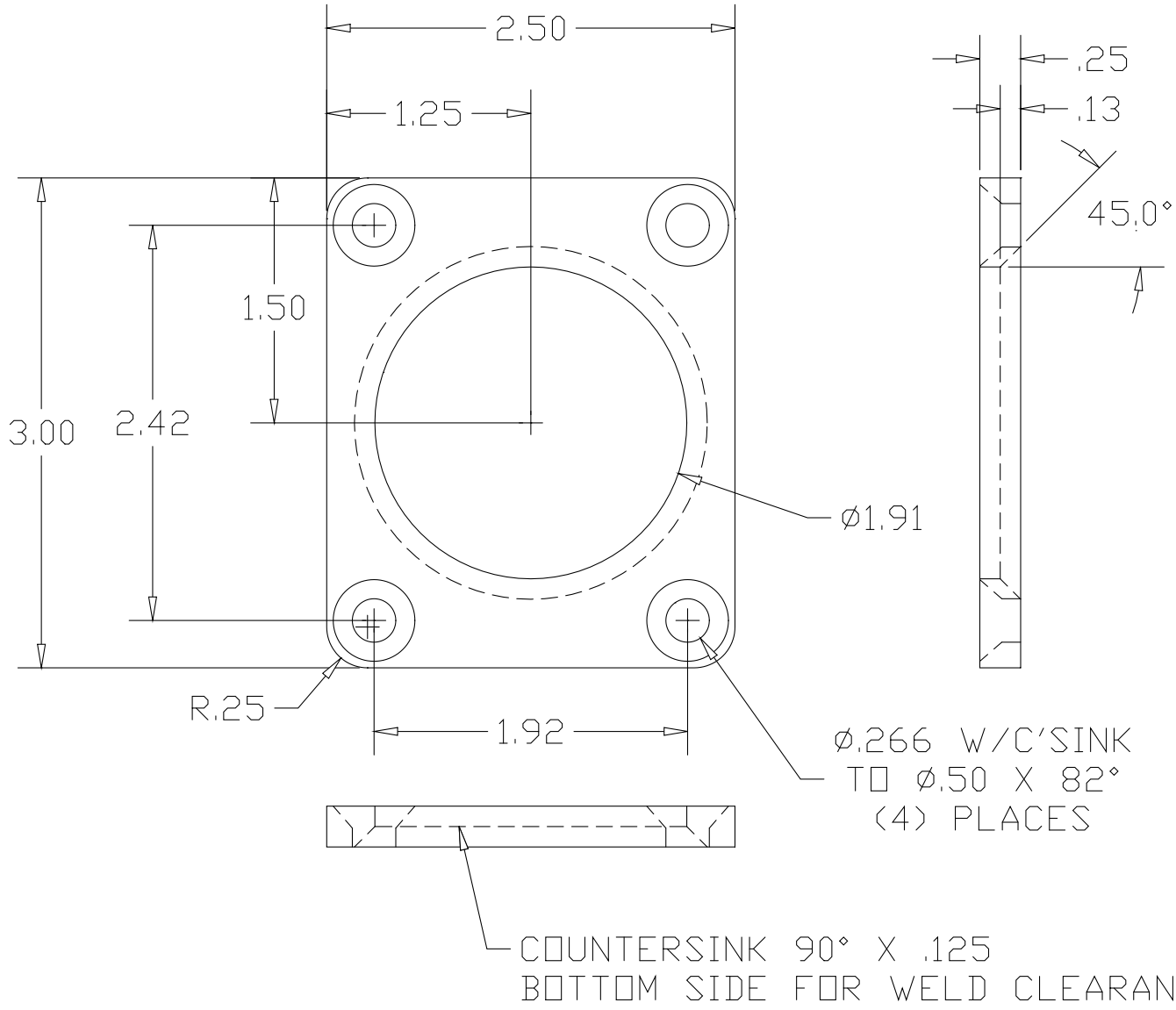

REV
SH
DWG NO

CRFLP2M

REVISIONS			
REV	DESCRIPTION	DATE	APPROVED



PART NAME		FLOOR PLATE 1.90" OD	
MATERIAL		.250 STEEL	
DATE	01/16/07	 THE WAGNER COMPANIES R & B WAGNER, INC. AND J. G. BRAUN CO.	REV
DRAWN BY	RJF		
FINISH	MILL		
SIZE	A	WEIGHT	PART NUMBER
			CRFLP2M