

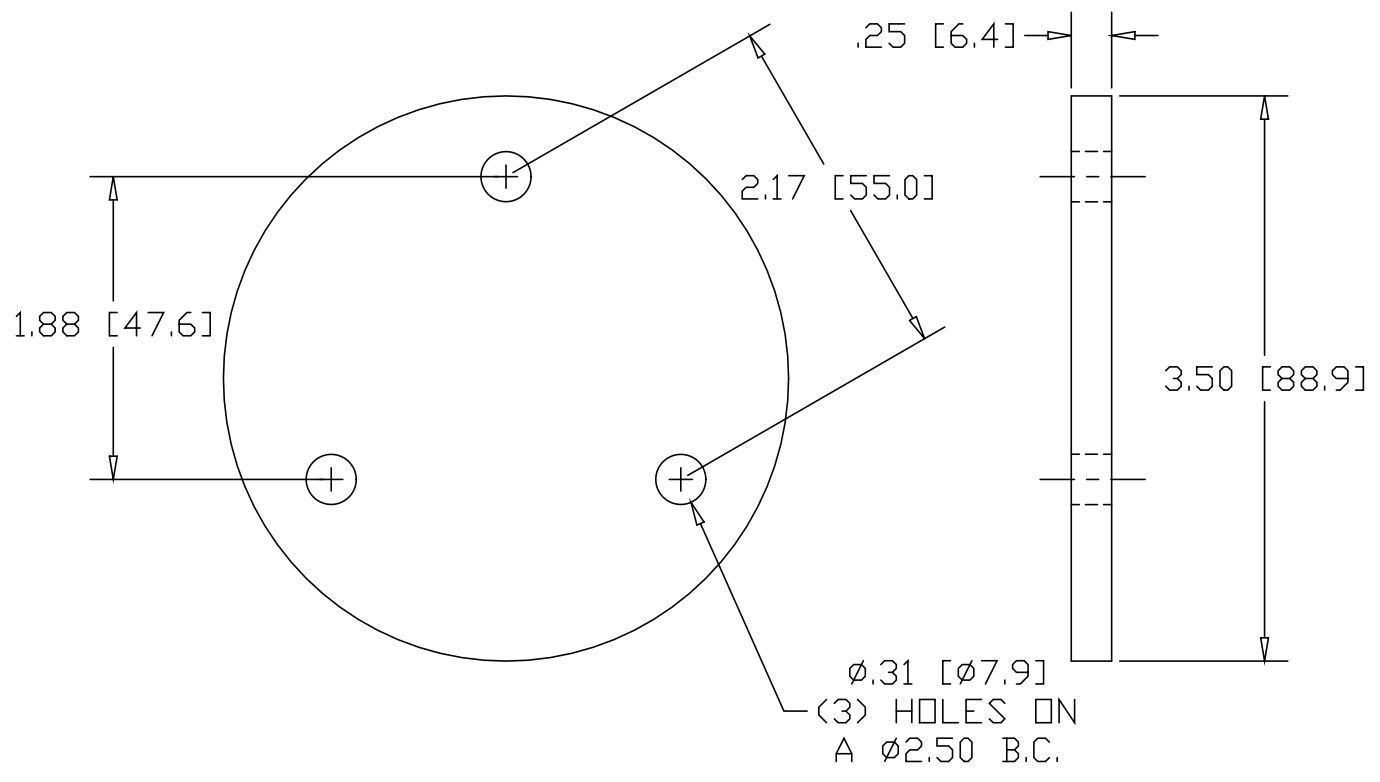

REV
SH
D173H
DWG NO

REVISIONS			
REV	DESCRIPTION	DATE	APPROVED



INCHES [MILLIMETERS]

ALTERNATE MATERIAL	PART NUMBER
.250 (3003) ALUMINUM ASTM B209	D174H
.250 (304) STAINLESS STEEL ASTM A240	D175H

PART NAME 3.50" BASE DISK WITH (3) MTG HOLES			
MATERIAL .250 HRP&O STEEL ASTM A569			
DATE 11/20/98	 THE WAGNER COMPANIES R & B WAGNER, INC. AND J. G. BRAUN CO.		
DRAWN BY RJF			
FINISH MILL		SIZE A	WEIGHT .64 LBS
		REV	