

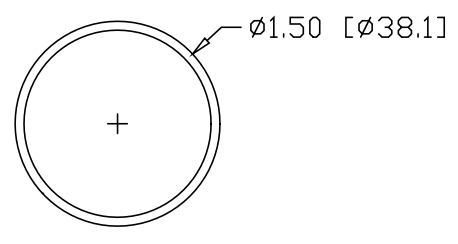

REV
SH
7908
DWG NO

REVISIONS			
REV	DESCRIPTION	DATE	APPROVED

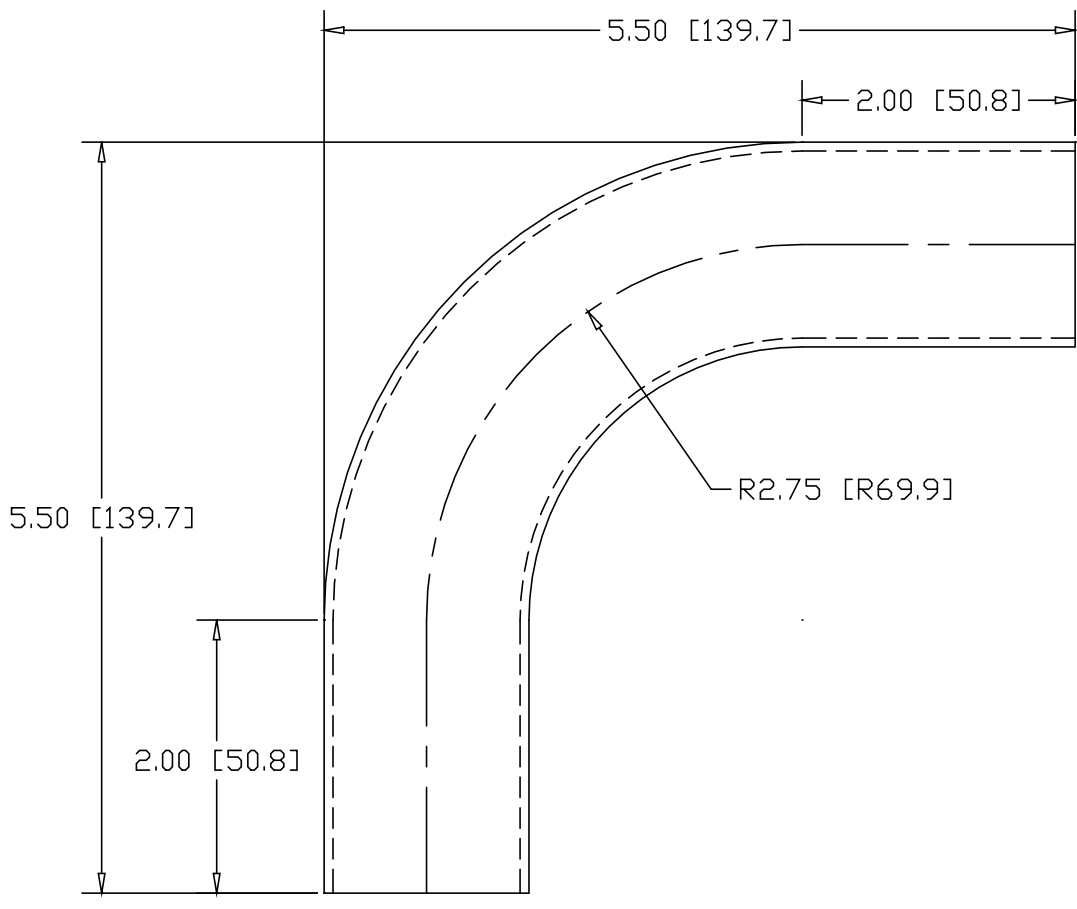

INCHES [MILLIMETERS]

ALTERNATE MATERIAL	PART NUMBER
1.50" O.D. X .125W (6061-T1) ALUMINUM TUBE	7924
1.50" O.D. X .065W (304) STAINLESS STEEL TUBE	7940

PART NAME 1.50" O.D. TUBE 90° ELL X 2.75"CLR W/(2) 2" TANGENTS			
MATERIAL 1.50" O.D. X .065W STEEL TUBE			
DATE 8/15/00		R & B WAGNER, INC.	
DRAWN BY RJF		SIZE A	WEIGHT .69 LBS
FINISH MILL			REV