

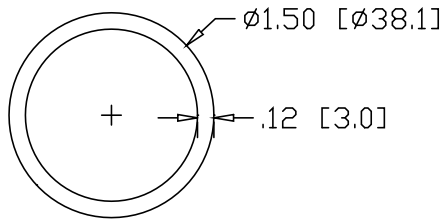

REV
SH
6907
DWG NO

REVISIONS			
REV	DESCRIPTION	DATE	APPROVED

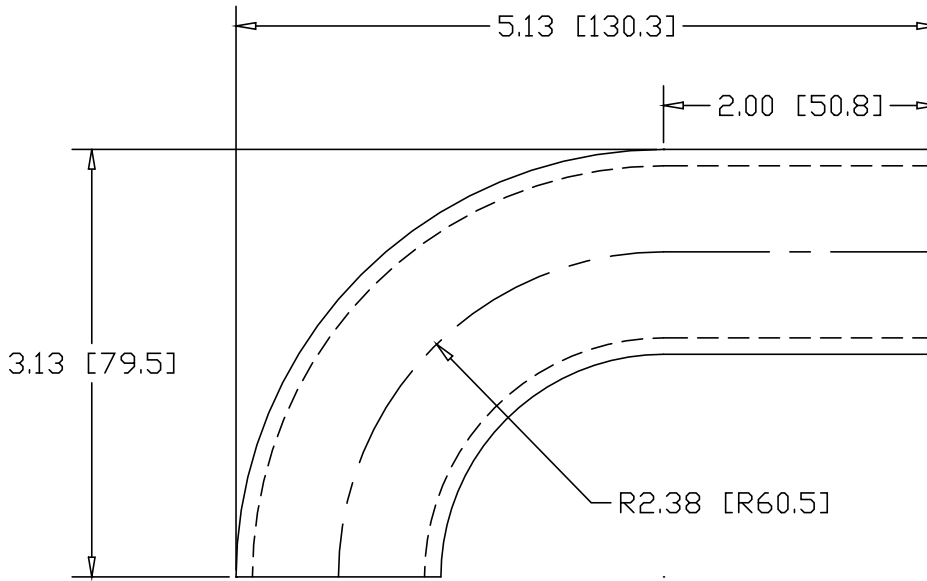

INCHES [MILLIMETERS]

ALTERNATE MATERIAL	PART NUMBER
1.50" O.D. X .125W (6061-T1) ALUMINUM TUBE	6923
1.50" O.D. X .120W (304) STAINLESS STEEL TUBE	6939

PART NAME 1.50" O.D. TUBE 90° ELL X 2.38" CLR W/(1) 2" TANGENT			
MATERIAL 1.50" O.D. X .120W STEEL TUBE			
DATE 9/12/00		R & B WAGNER, INC.	
DRAWN BY RJF		SIZE A	WEIGHT .86 LBS
FINISH MILL		PART NUMBER 6907	REV