

2



1

PARTS LIST

ITEM	QTY	PART NUMBER	DESCRIPTION
1	1	PGISO21	Cream Isolator, Plastic, Used with Panel Grip, 21.5mm Glass
2	1	PGISO.035	Red Pad, Used with Panel Grip, 21.5mm Glass
3	1	N/A	Panel Grip Assembly

B

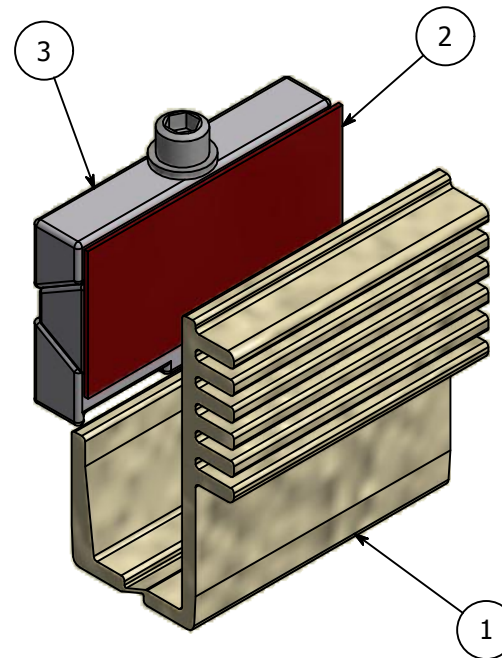
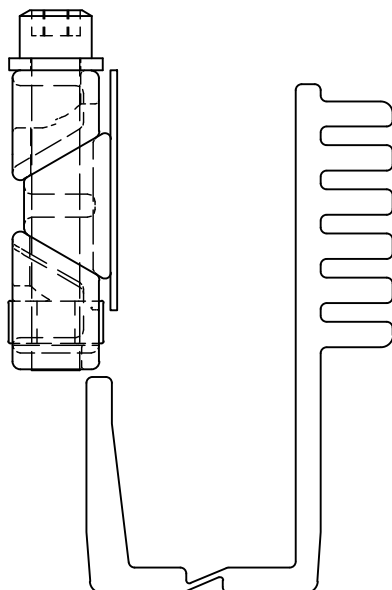
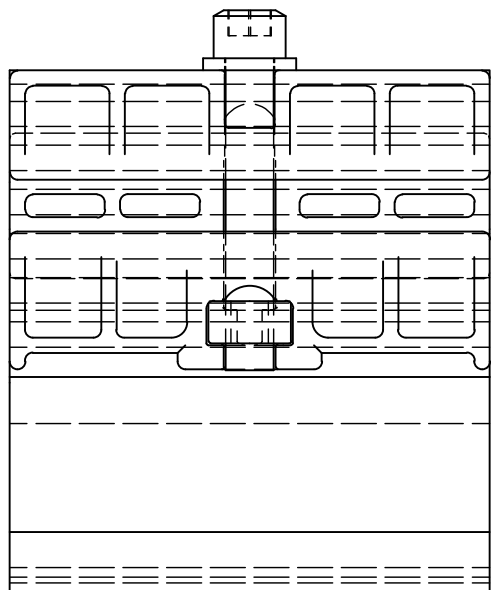

B

A

A

TOLERANCE X.X..... = ± .060 X.XX..... = ± .030 X.XXX..... = ± .010 XX°..... = ± 1° UNLESS OTHERWISE NOTED	CUT LENGTH:	FINISH:	DESCRIPTION: PanelGrip 2 for 21.5mm Glass, Dry Mount Mechanism, w/ Cream Isolator and Red Pad	
		As Is	MATERIAL:	MATERIAL DESC:
	DEVELOPED LENGTH:	WEIGHT:	DATE:	REV:
		0.26 lbmass	9/10/2015	1
TOOL NUMBER:		DRAWN BY:	PART NUMBER:	
		K. Bauserman	PG2421S	
			 COLLABORATIVE METAL WORKS	

2



1

2



1

PARTS LIST

ITEM	QTY	PART NUMBER	DESCRIPTION
1	1	GR2457HCBMKR	Shoe Moulding, AL, Corner, PanelGrip, 2-3/4 In Wide, 4-1/8 In High, Counterbored Holes
2	1	GR2457HCBMKL	Shoe Moulding, AL, Corner, PanelGrip, 2-3/4 In Wide, 4-1/8 In High, Counterbored Holes

B

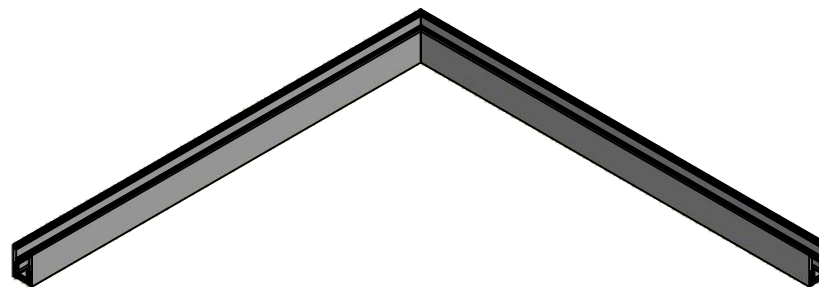
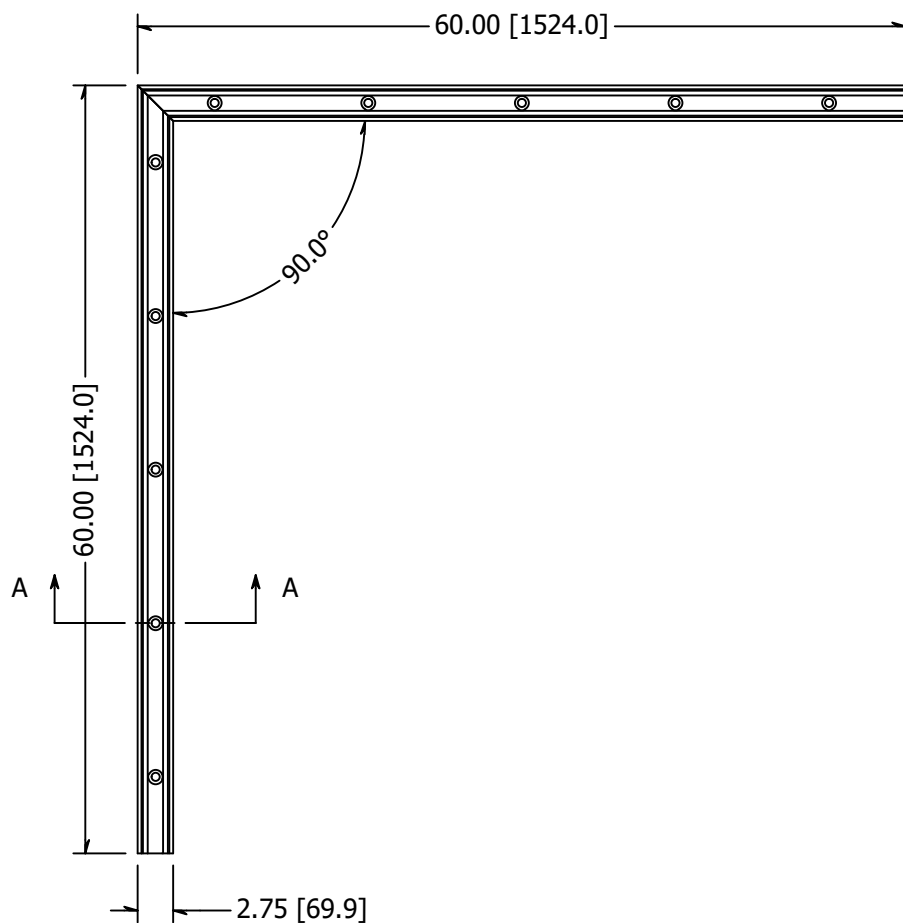

B

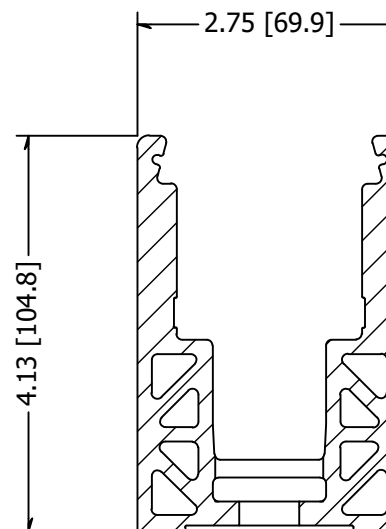

SECTION A-A

A

A

TOLERANCE UNLESS OTHERWISE NOTED, TOLERANCES TO CONFORM TO ES.03.011	MATERIAL: Aluminum	DESCRIPTION: Shoe Moulding, AL, Corner, PanelGrip, 2-3/4 In Wide, 4-1/8 In High, Counterbored Holes	
	FINISH: Mill	DATE: 6/17/2020	REV: -
	WEIGHT: 47.67 lbmass	DRAWN BY: T. Haapakoski	
		ITEM NUMBER: GR2457HCBMK	
		 10600 W Brown Deer Rd Milwaukee, WI 53224 COLLABORATIVE METALWORKS http://www.wagnercompanies.com/	

2



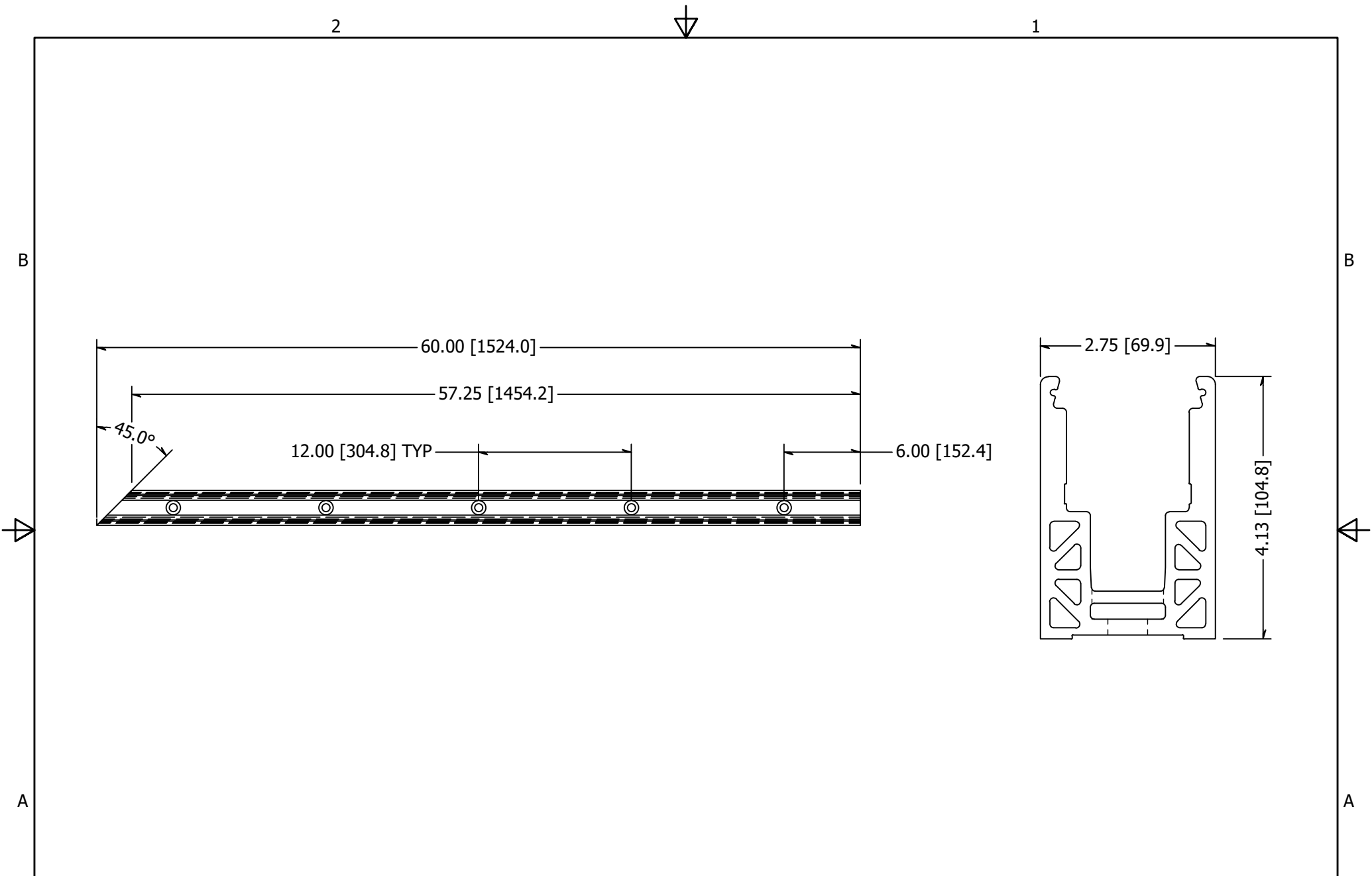

1

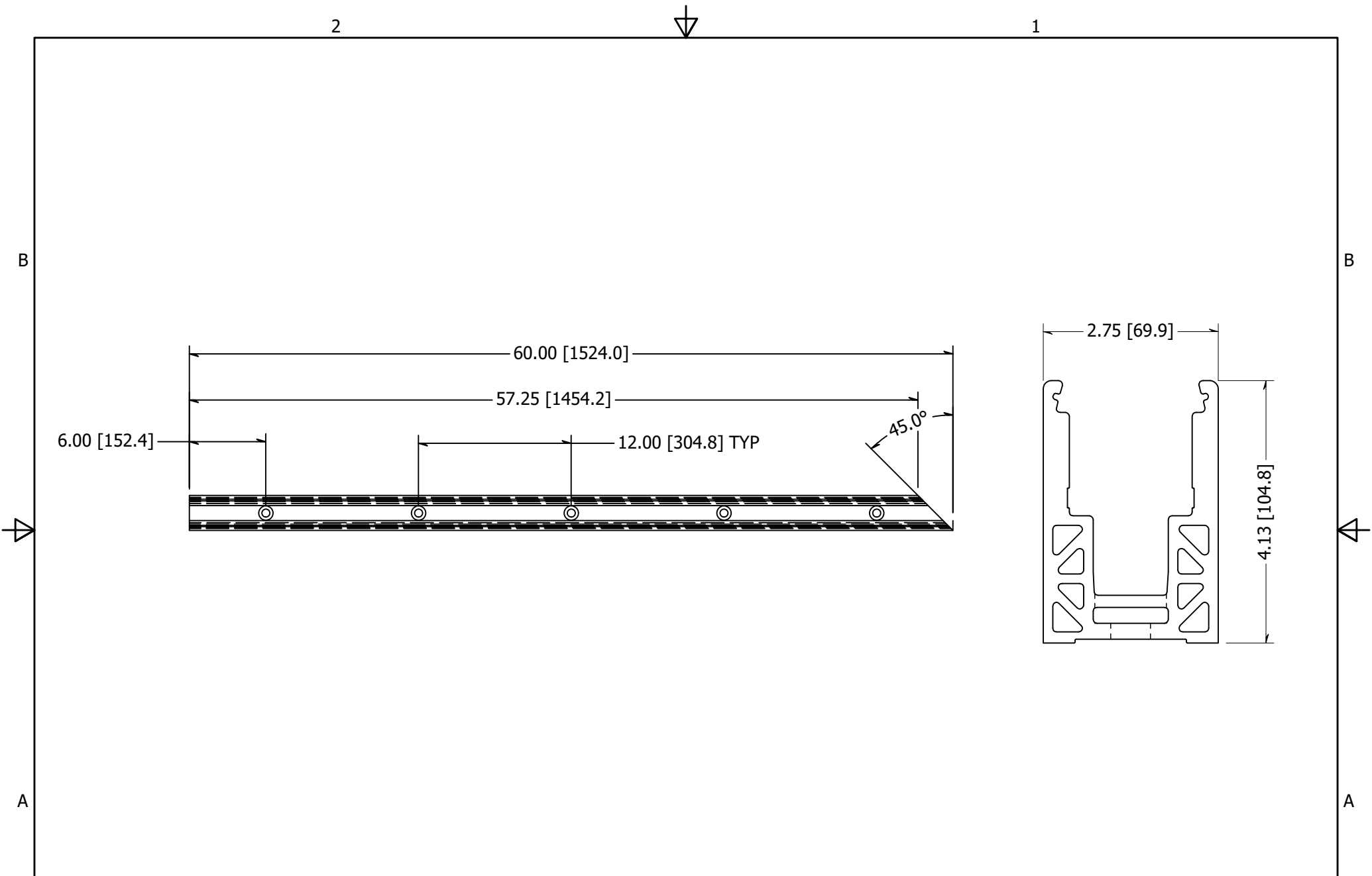

TOLERANCE UNLESS OTHERWISE NOTED, TOLERANCES TO CONFORM TO ES.03.011	CUT LENGTH:	FINISH:	DESCRIPTION: Shoe Moulding, AL, Corner, PanelGrip, 2-3/4 In Wide, 4-1/8 In High, Counterbored Holes	
	DEVELOPED LENGTH:	WEIGHT:	MATERIAL:	MATERIAL DESC:
	TOOL NUMBER:		DATE:	REV:
			DRAWN BY:	PART NUMBER:
		Mill	Aluminum	
		23.84 lbmass	6/17/2020	-
			T. Haapakoski	
			GR2457HCBMKL	

WAGNER™
 COLLABORATIVE METALWORKS
 10600 W Brown Deer Rd
 Milwaukee, WI 53224
<http://www.wagnercompanies.com/>



TOLERANCE UNLESS OTHERWISE NOTED, TOLERANCES TO CONFORM TO ES.03.011	CUT LENGTH:	FINISH:	DESCRIPTION: Shoe Moulding, AL, Corner, PanelGrip, 2-3/4 In Wide, 4-1/8 In High, Counterbored Holes	
		Mill	MATERIAL:	MATERIAL DESC:
	DEVELOPED LENGTH:	WEIGHT:	Aluminum	
		23.84 lbmass	DATE: 6/17/2020	REV: -
TOOL NUMBER:		DRAWN BY: T. Haapakoski	 WAGNER ™ 10600 W Brown Deer Rd Milwaukee, WI 53224 COLLABORATIVE METALWORKS http://www.wagnercompanies.com/	
		PART NUMBER: GR2457HCBMKR		

2

1

B

B

A

A

2

1