

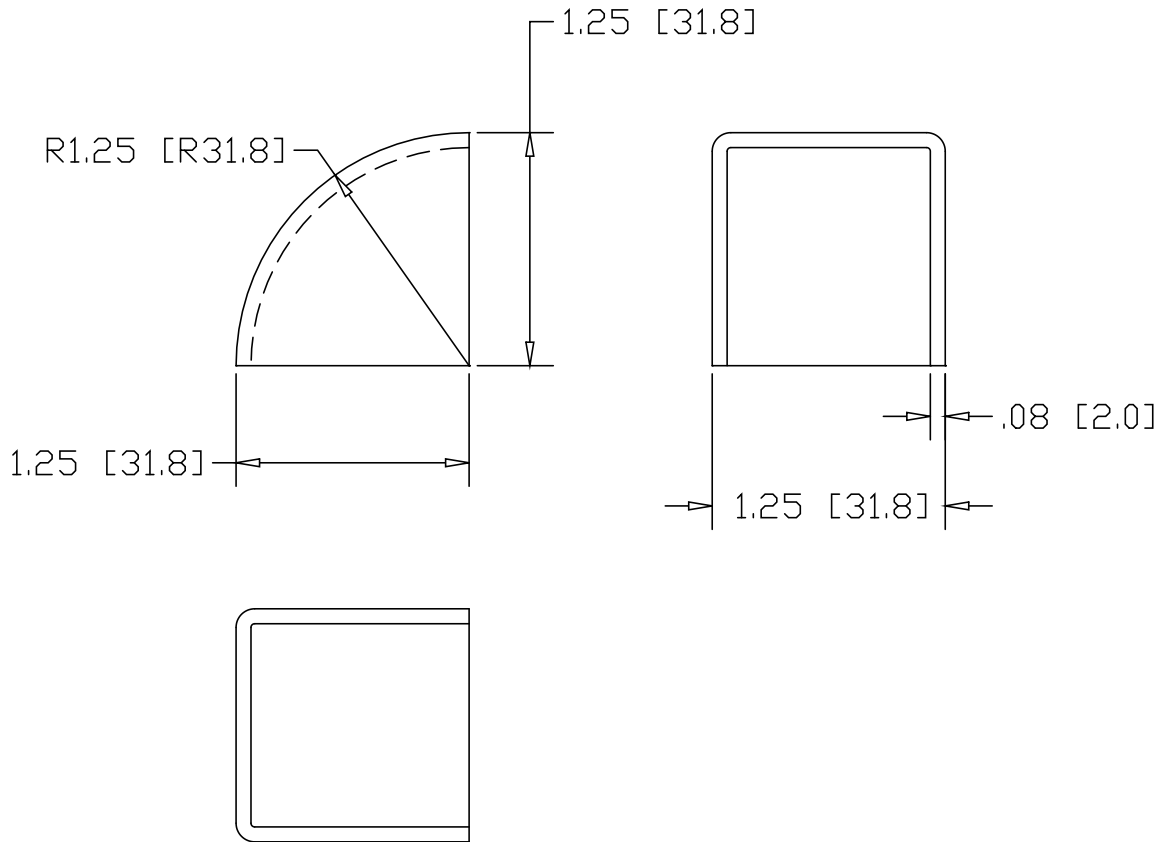

REV
SH
9215
DWG NO

REVISIONS			
REV	DESCRIPTION	DATE	APPROVED



INCHES [MILLIMETERS]

ALTERNATE MATERIAL	PART NUMBER
.080 (3003) ALUMINUM ASTM B209	9216
14 GA. (304) STAINLESS STEEL	9217
.083 (260) BRASS	9218

PART NAME		1-1/4" SQUARE TUBE CORNER					
MATERIAL		14 GA. HRP&D STEEL ASTM A569					
DATE	8/26/96		THE WAGNER COMPANIES R & B WAGNER, INC. AND J. G. BRAUN CO.				
DRAWN BY	RJF						
FINISH	MILL						
SIZE	A	WEIGHT	.09 LBS	PART NUMBER	9215	REV	