

REV
SH
4914
DWG NO

REVISIONS			
REV	DESCRIPTION	DATE	APPROVED

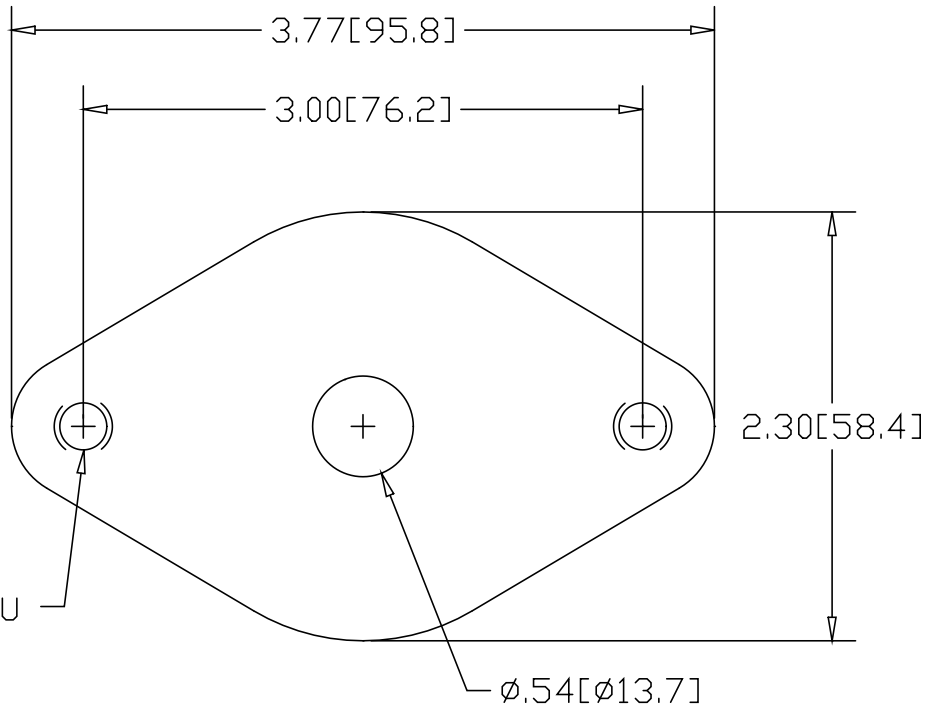

5/16-18 TAP THRU
(2) PLACES

0.54 [13.7]

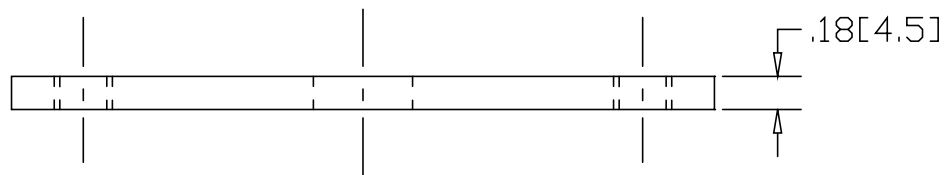

* INCLUDES (2) 5/16-18 X 3/8" ROUND HEAD MACHINE SCREWS

INCHES [MILLIMETERS]

ALTERNATE MATERIAL	PART NUMBER
.190 (3003) ALUMINUM ASTM B209	4944
7 GA. (304) STAINLESS STEEL ASTM A240	4974

PART NAME		TAPERED ANCHOR PLATE		
MATERIAL		7 GA. HRP&O STEEL ASTM A569		
DATE	7/10/95	 R & B WAGNER, INC.		
DRAWN BY	RJF			
FINISH	MILL	SIZE	WEIGHT	PART NUMBER
		A	.27 LBS	4914
				REV