

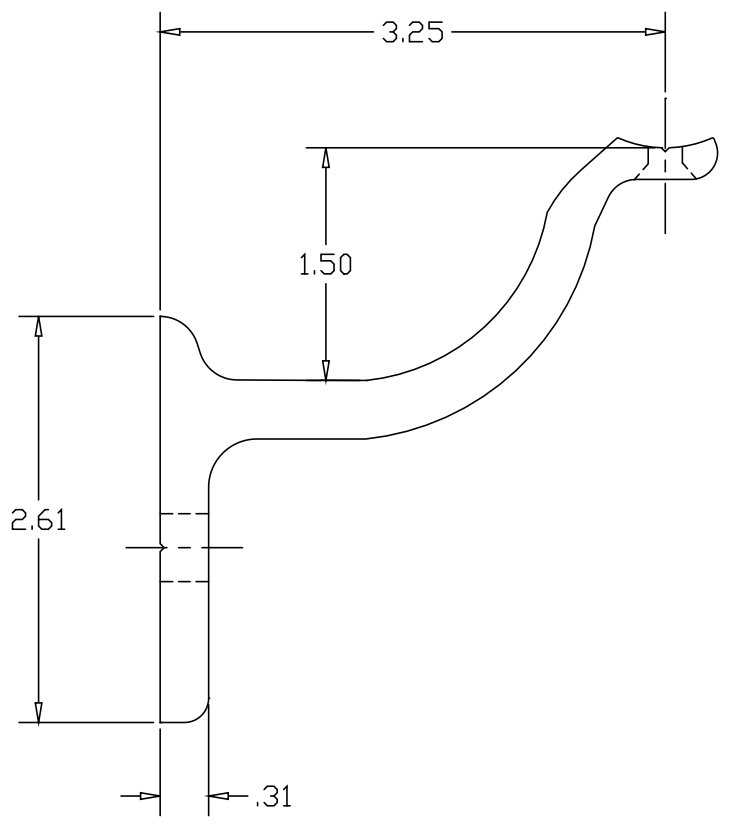

REVISIONS			
REV	DESCRIPTION	DATE	APPROVED

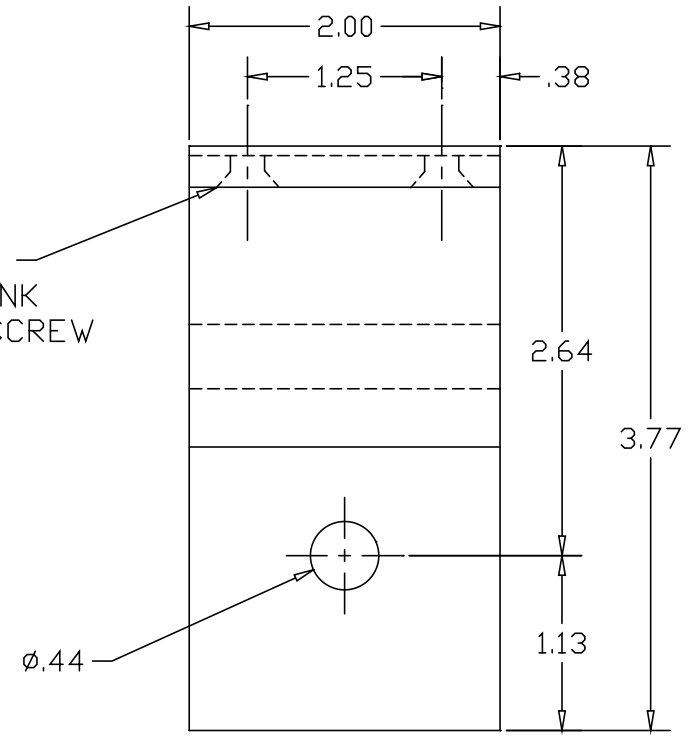

Ø.22 TYP  
WITH C'SINK  
FOR #10 SCREW  
(2) HOLES



PART NAME 3-1/4" EXTRUDED ALUM. HANDRAIL BRACKET W/1-1/2" CLEAR			
MATERIAL 6063-T52 ALUMINUM			
DATE	2/01/05	 <b>THE WAGNER COMPANIES</b> R & B WAGNER, INC. AND J. G. BRAUN CO.	
DRAWN BY	RDC		
FINISH	CLEAR ANODIZED	SIZE	A
		WEIGHT	
		PART NUMBER	ER8003A
		REV	