

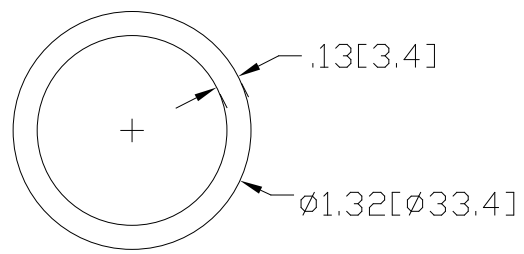

REV
SH
DWG NO 4509

REVISIONS			
REV	DESCRIPTION	DATE	APPROVED

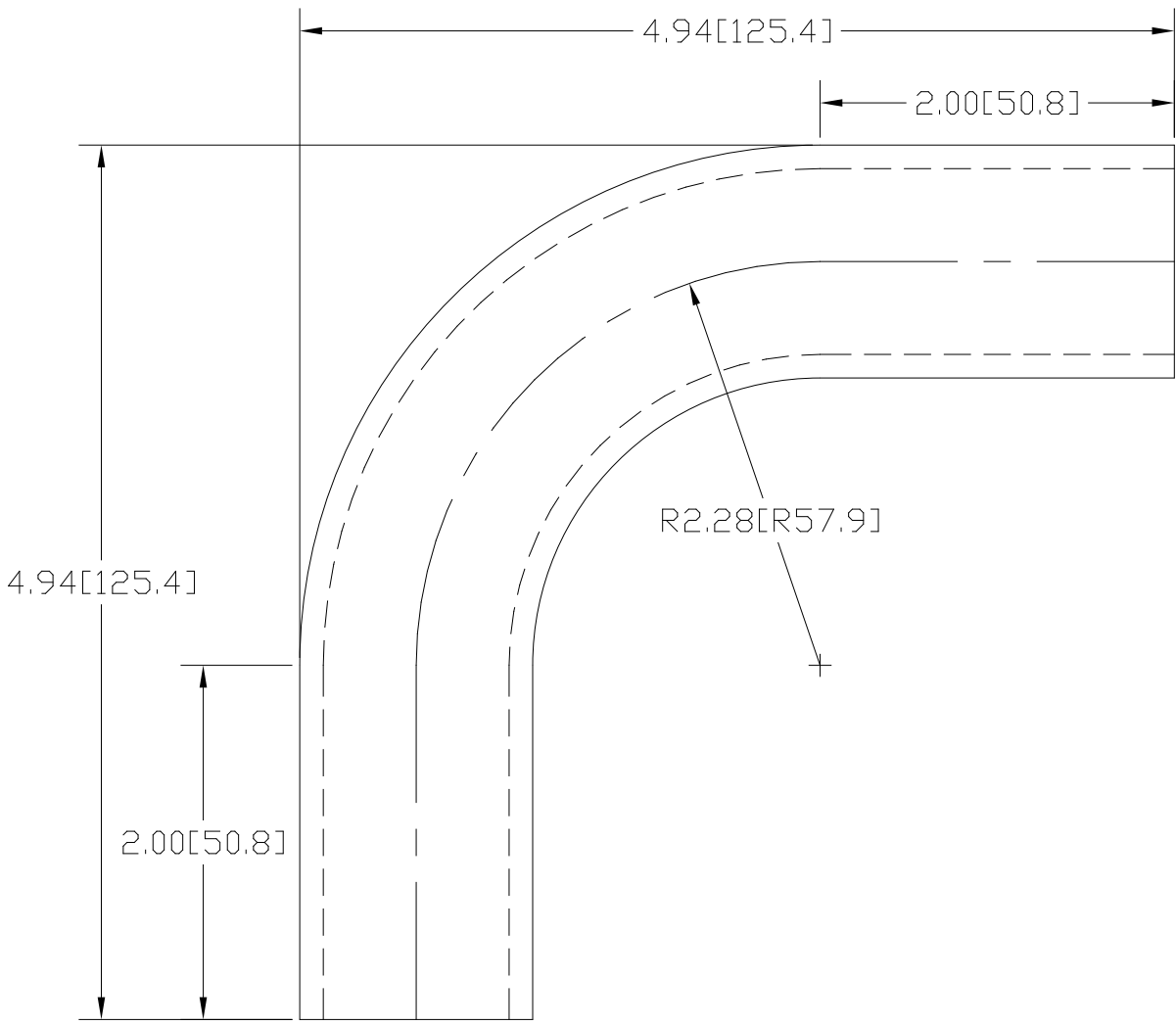

INCHES [MILLIMETERS]

ALTERNATE MATERIAL	PART NUMBER
1" SCH 40 (6063) ALUMINUM PIPE	4523
1" SCH 40 (304) STAINLESS STEEL PIPE	4537

PART NAME 1" PIPE SIZE 90° ELL X 1-5/8" I.R. W/(2) 2" TANGENTS				
MATERIAL 1" SCH 40 A53 STEEL PIPE				
DATE 8/18/95		THE WAGNER COMPANIES R & B WAGNER, INC. AND J. G. BRAUN CO.		
DRAWN BY RJF				
FINISH MILL	SIZE A	WEIGHT .80 LBS	PART NUMBER 4509	REV