

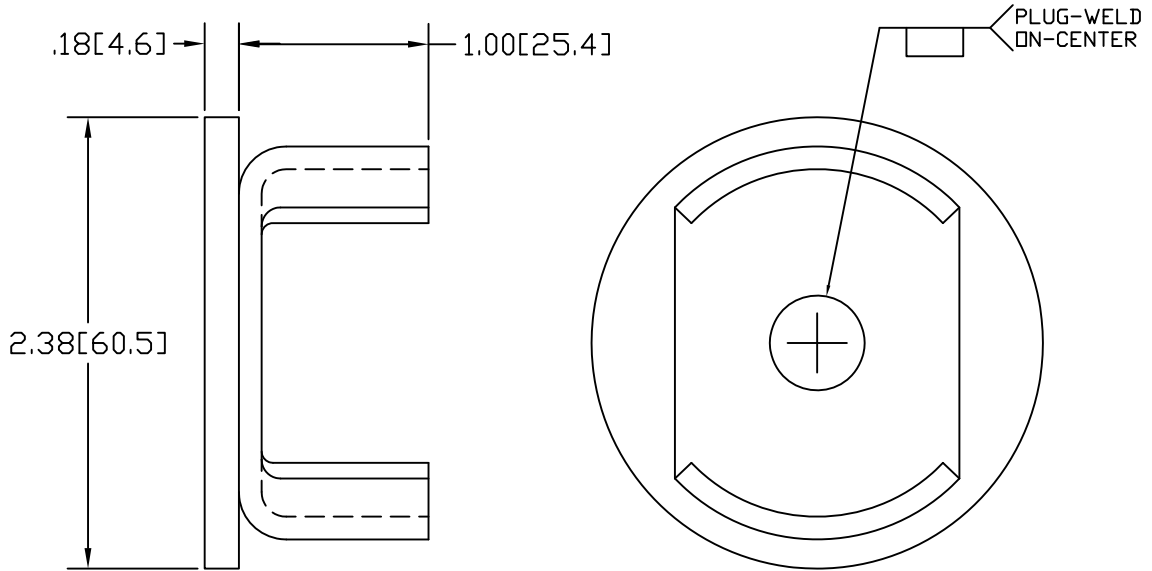

REV A  
SH  
DWG NO 3293

| REVISIONS |                 |          |          |
|-----------|-----------------|----------|----------|
| REV       | DESCRIPTION     | DATE     | APPROVED |
| A         | ADDED PLUG WELD | 09/03/15 | RJF      |



INCHES [MILLIMETERS]

| ALTERNATE MATERIAL | PART NUMBER |
|--------------------|-------------|
|                    |             |
|                    |             |

|           |          |   |         |             |
|-----------|----------|---|---------|-------------|
| PART NAME |          | 2" PIPE SIZE TYPE-E DRIVE-ON DISK   |         |             |
| MATERIAL  |          | .190 (3003) ALUMINUM ASTM B209  |         |             |
| DATE      | 10/11/96 |  <b>THE WAGNER COMPANIES</b><br>R & B WAGNER, INC. AND J. G. BRAUN CO. |         |             |
| DRAWN BY  | RJF      |   |         |             |
| FINISH    | MILL     | SIZE  | WEIGHT  | PART NUMBER |
|           |          | A   | .15 LBS | 3293        |
|           |          |   |         | REV A       |