

REV
SH
1438
DWG NO

REVISIONS			
REV	DESCRIPTION	DATE	APPROVED

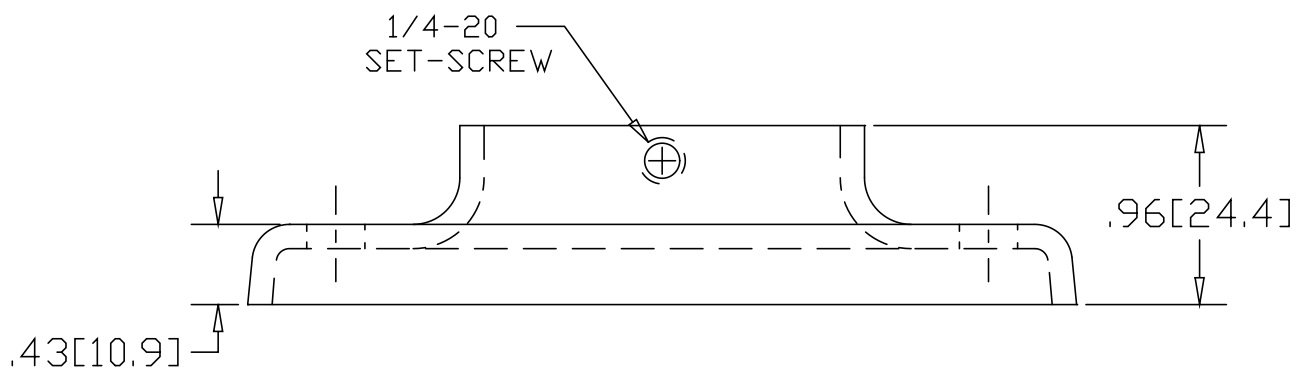
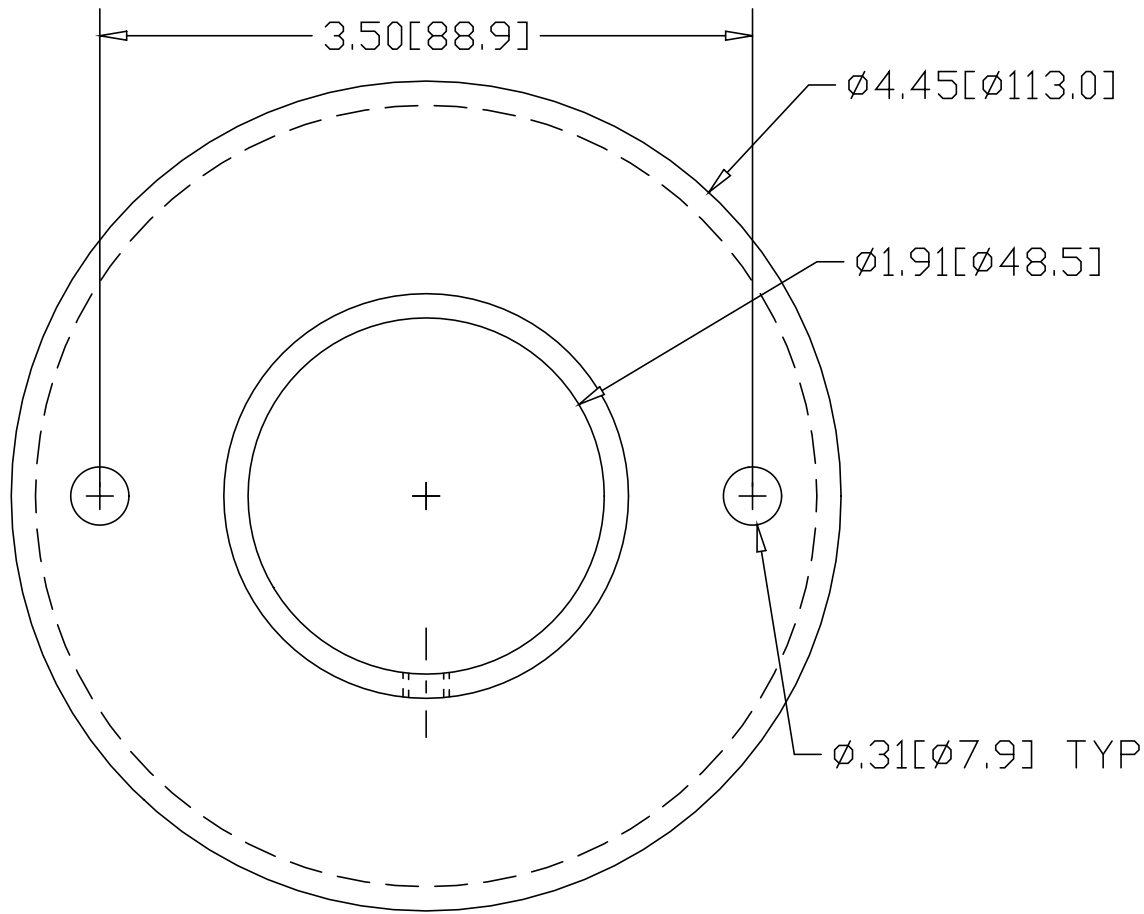

INCHES [MILLIMETERS]

ALTERNATE MATERIAL	PART NUMBER
.125 (3003) ALUMINUM ASTM B209	1478
10 GA. (304) STAINLESS STEEL ASTM A240	1538

PART NAME 1-1/2" PIPE HEAVY BASE FLANGE W/(2) HOLES & SET-SCREW			
MATERIAL 10 GA. HRP&D STEEL ASTM A569			
DATE 9/13/94	WAGNER	R & B WAGNER, INC.	
DRAWN BY RJF			
FINISH MILL	SIZE A	WEIGHT .64 LBS	PART NUMBER 1438
			REV