

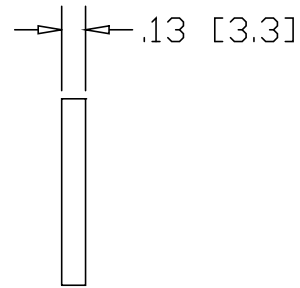

DWG NO 3206-1
SH
REV

REVISIONS			
REV	DESCRIPTION	DATE	APPROVED

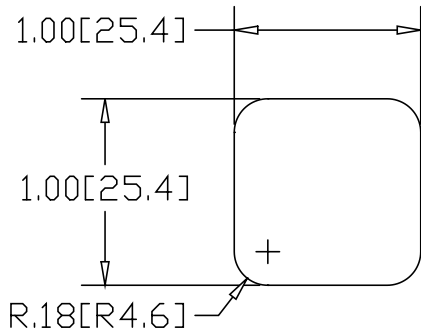

INCHES [MILLIMETERS]

ALTERNATE MATERIAL	PART NUMBER
.125 (3003) ALUMINUM ASTM B209	3206-1A
11 GA. 304 STAINLESS STEEL	3206-1SS
.1875 (260) BRASS ASTM B19,B36	BRS3206-1

PART NAME		1.00" SQUARE WELD-ON CAP					
MATERIAL		10 GA. HRP&D STEEL ASTM A569					
DATE	5/18/98	 THE WAGNER COMPANIES R & B WAGNER, INC. AND J. G. BRAUN CO.					
DRAWN BY	RJF						
FINISH	MILL						
SIZE	A	WEIGHT	.05 LBS	PART NUMBER	3206-1	REV	