

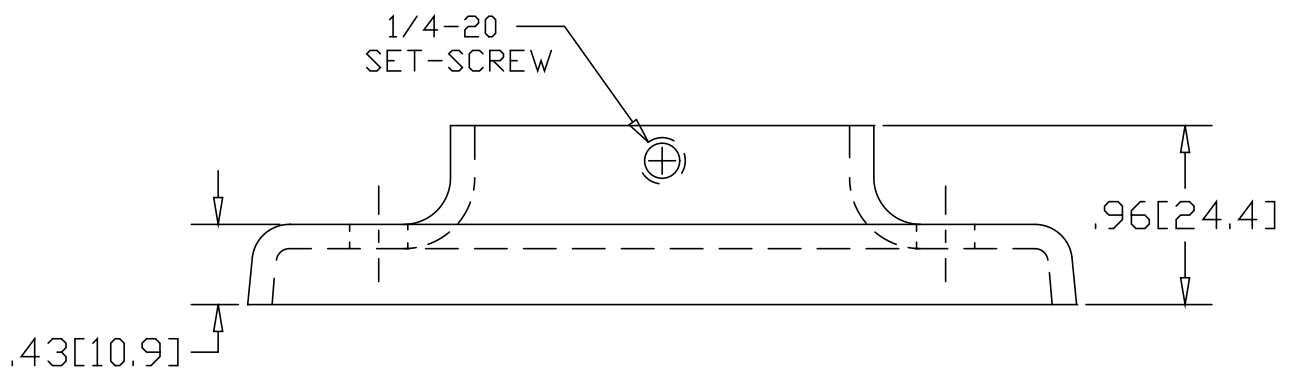

REV
SH
1446AT
DWG NO

REVISIONS			
REV	DESCRIPTION	DATE	APPROVED

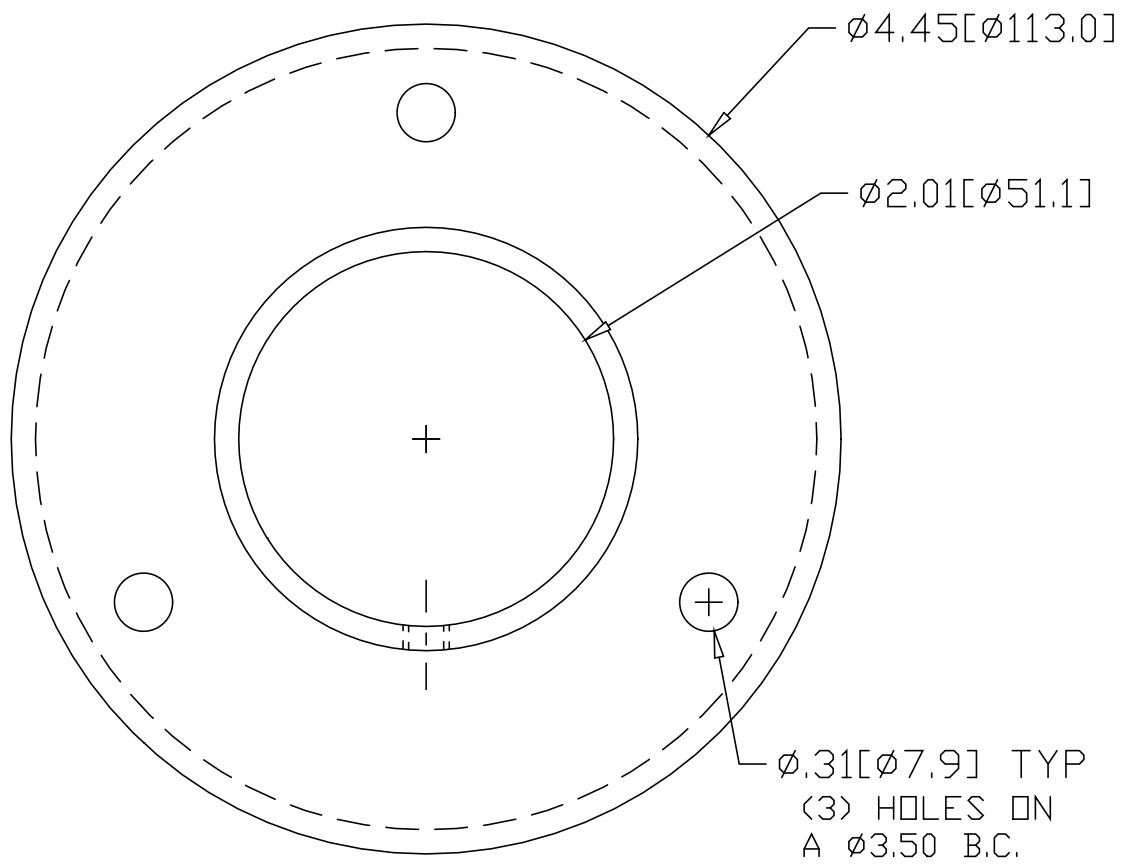

INCHES [MILLIMETERS]

ALTERNATE MATERIAL	PART NUMBER
.125 (3003) ALUMINUM ASTM B209	1486AT
10 GA. (304) STAINLESS STEEL ASTM A240	1546AT

PART NAME 2.00" OD TUBE HEAVY BASE FLANGE W/(3) HOLES & SET-SCREW				
MATERIAL 10 GA. HRP&D STEEL ASTM A569				
DATE 9/13/94		R & B WAGNER, INC.		
DRAWN BY RJF		FINISH MILL	SIZE A	WEIGHT .64 LBS
		PART NUMBER	1446AT	REV