

REVISION HISTORY			
REV	DESCRIPTION	DATE	APPROVED
A	CAP 3221 WAS G3213	08/20/2021	RJF
2	BRSP HOLE CENTER DISTANCE INCREASED TO 12.3"	3/14/2023	WEP

TOLERANCE UNLESS OTHERWISE NOTED, TOLERANCES TO CONFORM TO ES.03.011	MATERIAL: STEEL	DESCRIPTION: Bike Rack, Steel, Stanchion, 2" sch 40, Surface Mount, Hot Dip Galvanized	
	FINISH: HOT DIP GALVANIZED	DATE: 6/20/2023	REV: 2
	WEIGHT: 18.34 lbmass	DRAWN BY: W. Purgill	WAGNER COLLABORATIVE METALWORKS
		ITEM NUMBER: BRS	

10600 W Brown Deer Rd
Milwaukee, WI 53224
<http://www.wagnercompanies.com/>

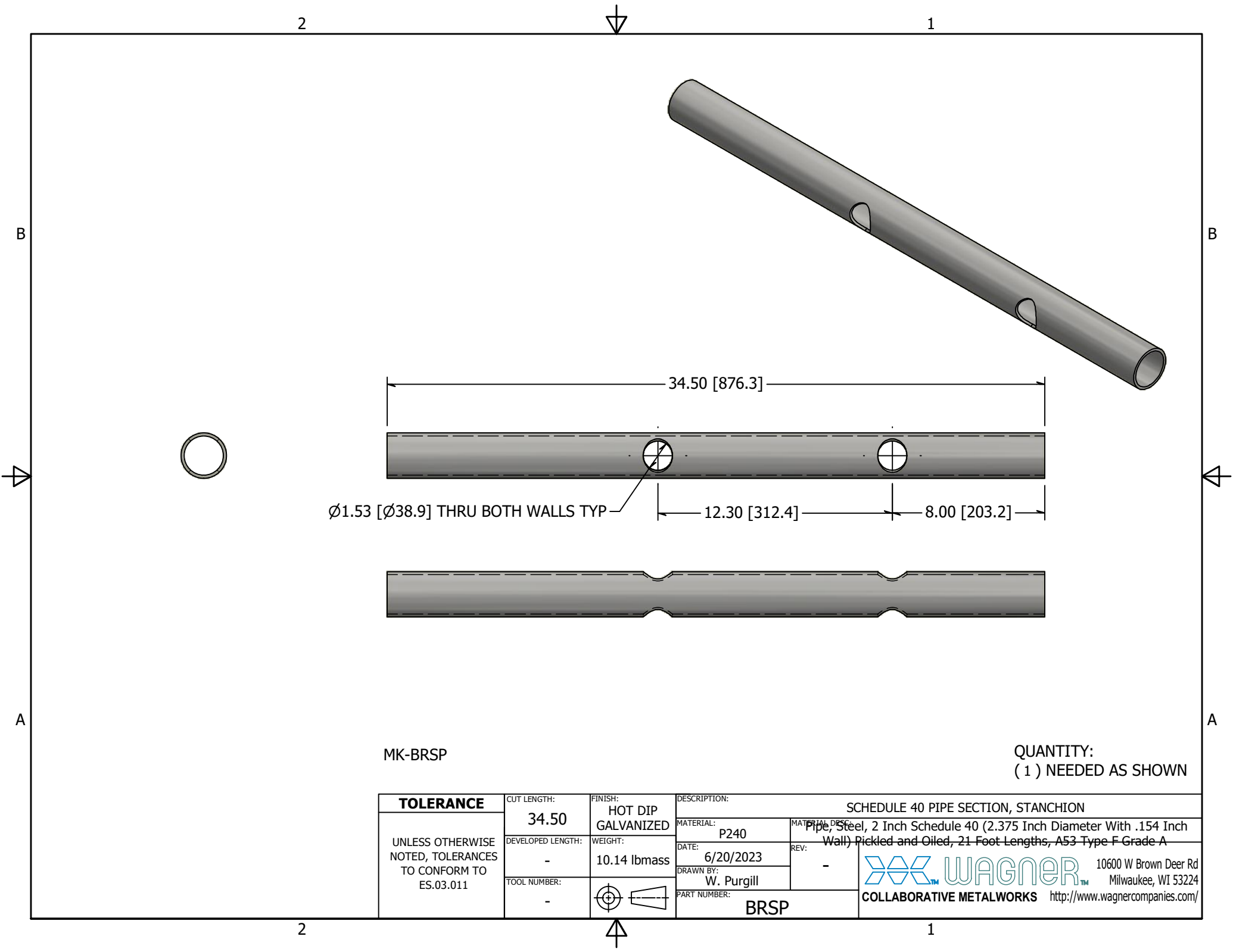

Ø1.53 [Ø38.9] THRU BOTH WALLS TYP

34.50 [876.3]

12.30 [312.4]

8.00 [203.2]

MK-BRSP

QUANTITY:
(1) NEEDED AS SHOWN

TOLERANCE UNLESS OTHERWISE NOTED, TOLERANCES TO CONFORM TO ES.03.011	CUT LENGTH:	FINISH:	DESCRIPTION:	
	34.50	HOT DIP GALVANIZED	SCHEDULE 40 PIPE SECTION, STANCHION	
	DEVELOPED LENGTH:	WEIGHT:	MATERIAL:	MATERIAL DESCRIPTION:
	-	10.14 lbmass	P240	Pipe, Steel, 2 Inch Schedule 40 (2.375 Inch Diameter With .154 Inch Wall) Pickled and Oiled, 21 Foot Lengths, A53 Type F Grade A
TOOL NUMBER:		DATE:	DRAWN BY:	REV:
-		6/20/2023	W. Purgill	-
			PART NUMBER:	
			BRSP	



 10600 W Brown Deer Rd
 Milwaukee, WI 53224
<http://www.wagnercompanies.com/>

2

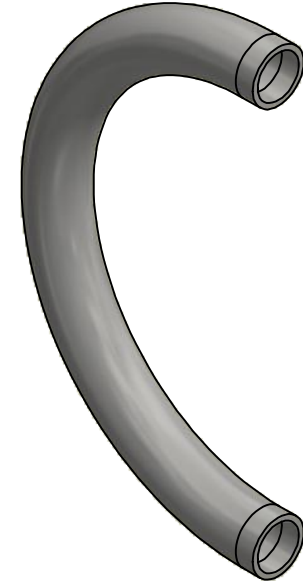
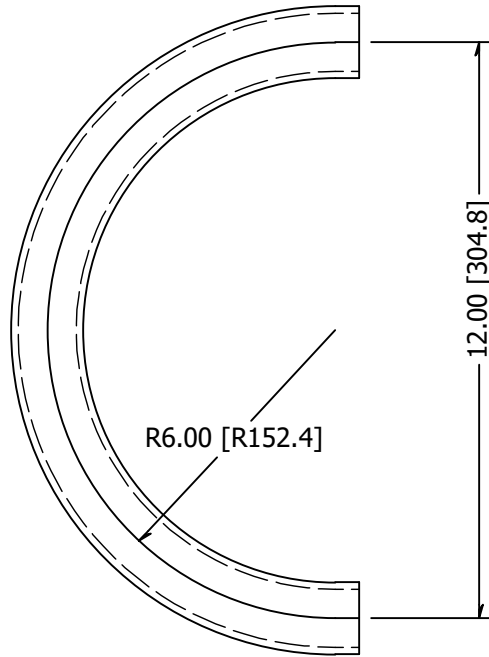

1

B



B

A

A

MK-BRSL
MAKE FROM ELBOW 6963-6B

QUANTITY:
(2) NEEDED AS SHOWN

TOLERANCE	CUT LENGTH:	FINISH:	DESCRIPTION:		
	37	#4 Satin	BD ST 1.50 .120W 6.00CLR 180D TRIMMED FOR STANCHION BIKE RACK		
	UNLESS OTHERWISE NOTED, TOLERANCES TO CONFORM TO ES.03.011	DEVELOPED LENGTH:	WEIGHT:	MATERIAL:	MATERIAL DESC:
		36 7/8	3.47 lbmass	T1300	1-1/2 Schd 40 Pipe 304 SS 1.90 OD .145 Wall 21 Ft.
TOOL NUMBER:			DATE:	REV:	
TL1056			6/20/2023		
			DRAWN BY:	PART NUMBER:	
			W. Purgill	BRSL	



2



1

2

1

B

B

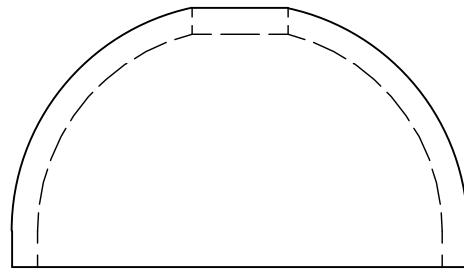
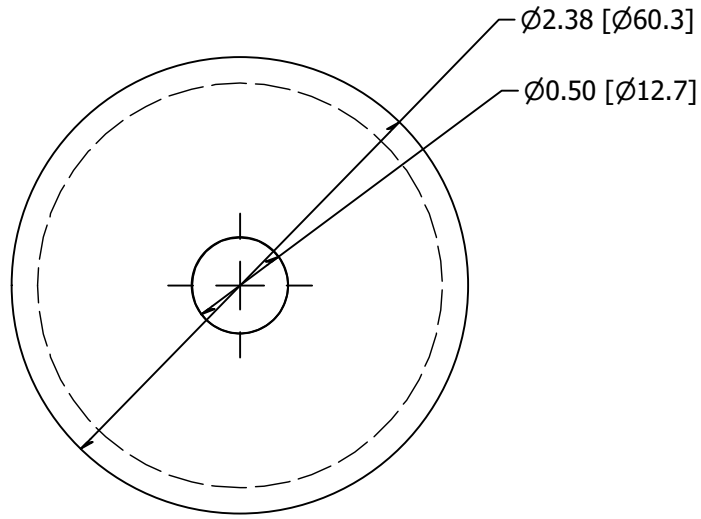

A

A

MK-BRSC
REF CAP 3221

QUANTITY:
(1) NEEDED AS SHOWN

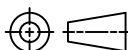
TOLERANCE UNLESS OTHERWISE NOTED, TOLERANCES TO CONFORM TO ES.03.011	CUT LENGTH:	FINISH:	DESCRIPTION:	
	-	HOT DIPPED GALVANIZED	End Cap Steel Domed 2.375 Weld-On with Weep Hole for Stanchion Bike Rack	
	DEVELOPED LENGTH:	WEIGHT:	MATERIAL:	MATERIAL SPEC:
	-	0.34 lbmass	C7100	Coil, Steel, .170-.180 X 8.000 Hot Rolled, Pickled and Oiled, Drawn Quality, 201d 48-50 Diameter ASTM A1011
TOOL NUMBER:		DATE:	REV:	 10600 W Brown Deer Rd Milwaukee, WI 53224 COLLABORATIVE METALWORKS http://www.wagnercompanies.com/
TL8729		6/20/2023	-	
		DRAWN BY:	PART NUMBER:	
		W. Purgill	BRSC	

2

1



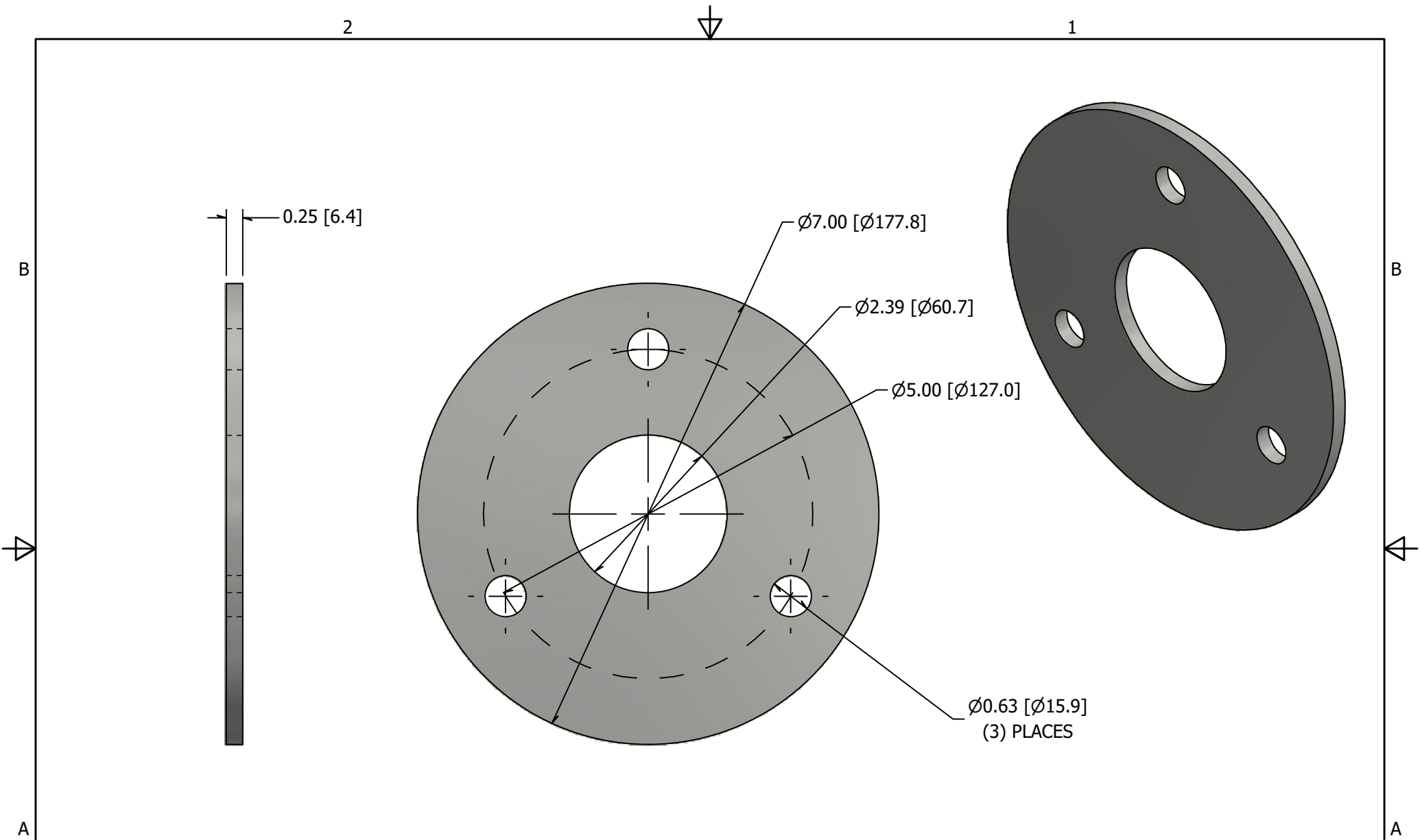

MK-BRSF

QUANTITY:
(1) NEEDED AS SHOWN

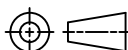
TOLERANCE UNLESS OTHERWISE NOTED, TOLERANCES TO CONFORM TO ES.03.011	CUT LENGTH:	FINISH:	DESCRIPTION:	
	-	HOT DIP GALVANIZED	FLC ST .250 BIKE RACK FLANGE, STANCHION	
	DEVELOPED LENGTH:	WEIGHT:	MATERIAL:	MATERIAL DESC:
	-	2.41 lbmass	S380	Sheet, Steel, .250 (.237-.250) Hot Rolled, Pickled and Oiled CS Type B ASTM A1018 48 X 120
TOOL NUMBER:		DATE:	REV:	 WAGNER COLLABORATIVE METALWORKS
-		6/20/2023	-	
		DRAWN BY:	10600 W Brown Deer Rd Milwaukee, WI 53224 http://www.wagnercompanies.com/	
		W. Purgill		
		PART NUMBER:	BRSF	