

REV  
SH  
2637  
DWG NO

REVISIONS			
REV	DESCRIPTION	DATE	APPROVED

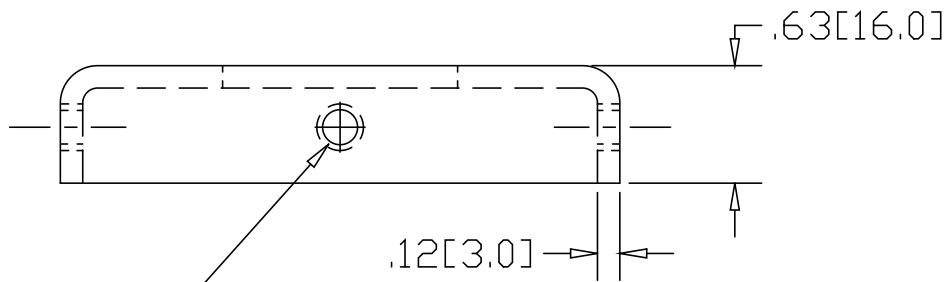
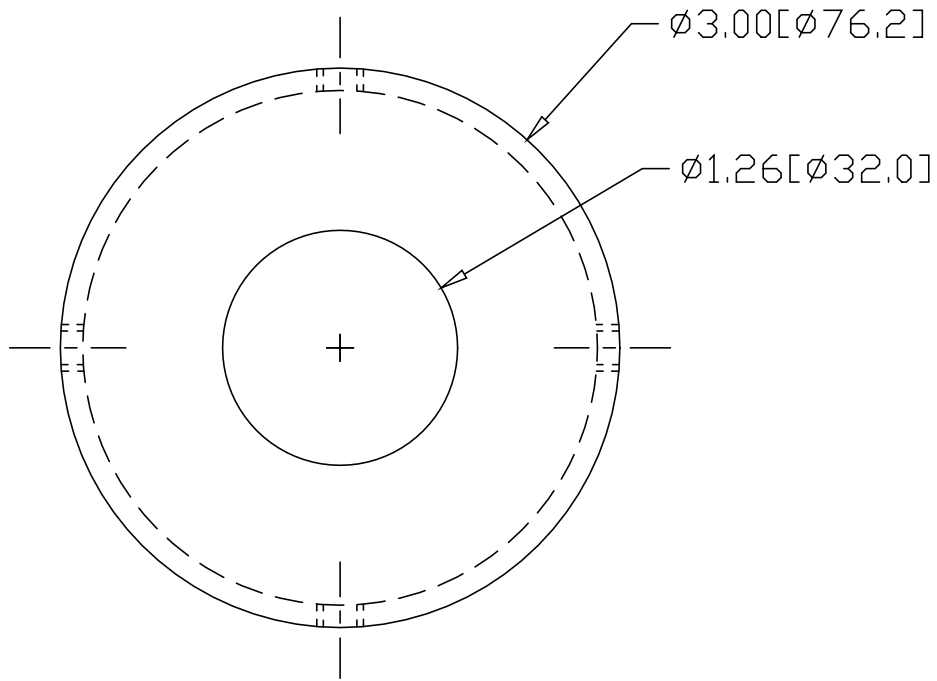

1/4-20 SET-SCREW  
(4) PLACES (INCLUDED)

\* INCLUDES ANCHOR PLATE AND (4) SET-SCREWS

INCHES [MILLIMETERS]

ALTERNATE MATERIAL	PART NUMBER
11 GA. (304) STAINLESS STEEL ASTM A-240	2631
.125 (260) BRASS	BRS2637

PART NAME		1.25" O.D. TUBE CONCEALED MOUNTING FLANGE		
MATERIAL		11 GA. HRP&D STEEL ASTM A-569		
DATE	5/31/95	 <b>R &amp; B WAGNER, INC.</b>		
DRAWN BY	RJF			
FINISH	MILL	SIZE	WEIGHT	PART NUMBER
		A	.3 LBS	2637
				REV