

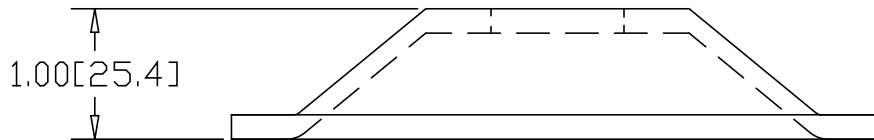

REV
SH
DWG NO 8053-NH

REVISIONS			
REV	DESCRIPTION	DATE	APPROVED

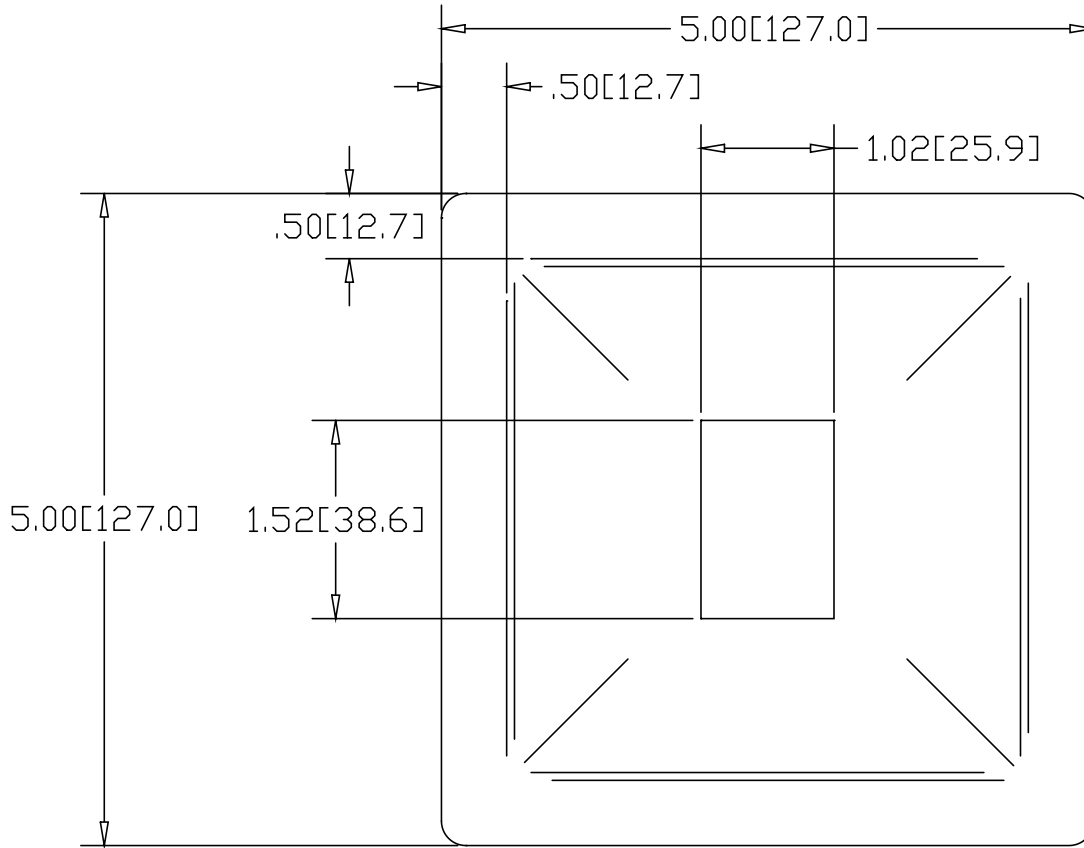

INCHES [MILLIMETERS]

ALTERNATE MATERIAL	PART NUMBER
.190 (3003) ALUMINUM ASTM B209	8054-NH

PART NAME 1" X 1-1/2" RECTANGULAR TUBE FLANGE			
MATERIAL 7 GA. HRP&D STEEL ASTM A569			
DATE 6/12/96	 R & B WAGNER, INC.		
DRAWN BY RJF			
FINISH MILL	SIZE A	WEIGHT 1.2 LBS	PART NUMBER 8053-NH
			REV