

REV
SH
DWG NO

REVISIONS			
REV	DESCRIPTION	DATE	APPROVED

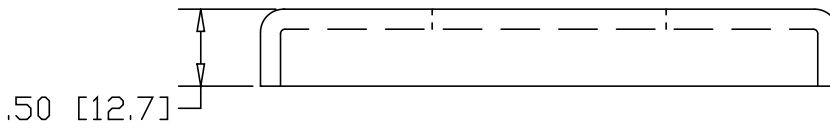
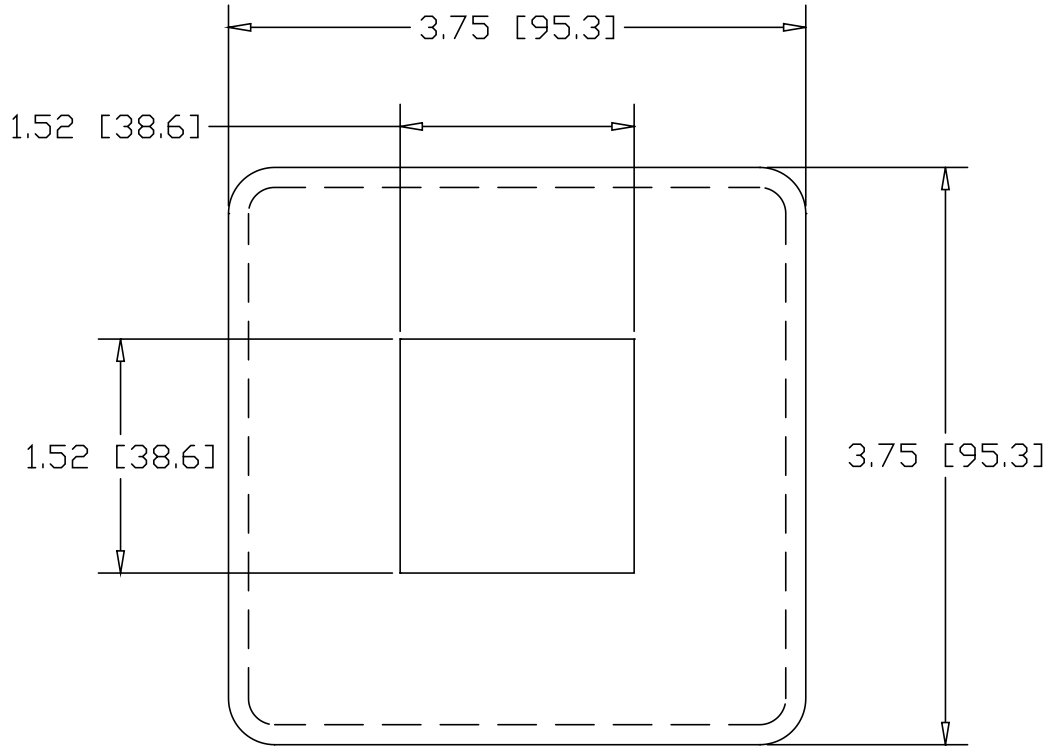

INCHES [MILLIMETERS]

UNLESS OTHERWISE SPECIFIED, DIMENSIONS ON THIS DRAWING ARE SUBJECT TO THE TOLERANCES SPECIFIED IN THE WAGNER QUALITY CLASSIFICATION CIRCLED BELOW PER WAGNER ENGINEERING SPEC ES.03.001.R1

WAGNER QUALITY CLASSIFICATION		
A	B	C

MATERIAL		11GA. SHEET STAINLESS STEEL 316L-2B ASTM A240		
CUSTOMER		PART NAME		
DATE 8/02/07		1-1/2" SQUARE TUBE HFB FLANGE		
DRAWN BY RDC		 THE WAGNER COMPANIES R & B WAGNER, INC. AND J. G. BRAUN CO.		
FINISH				
#4 SATIN		SIZE	JOB NUMBER	PART NUMBER
		A		8862.316.4
				REV