

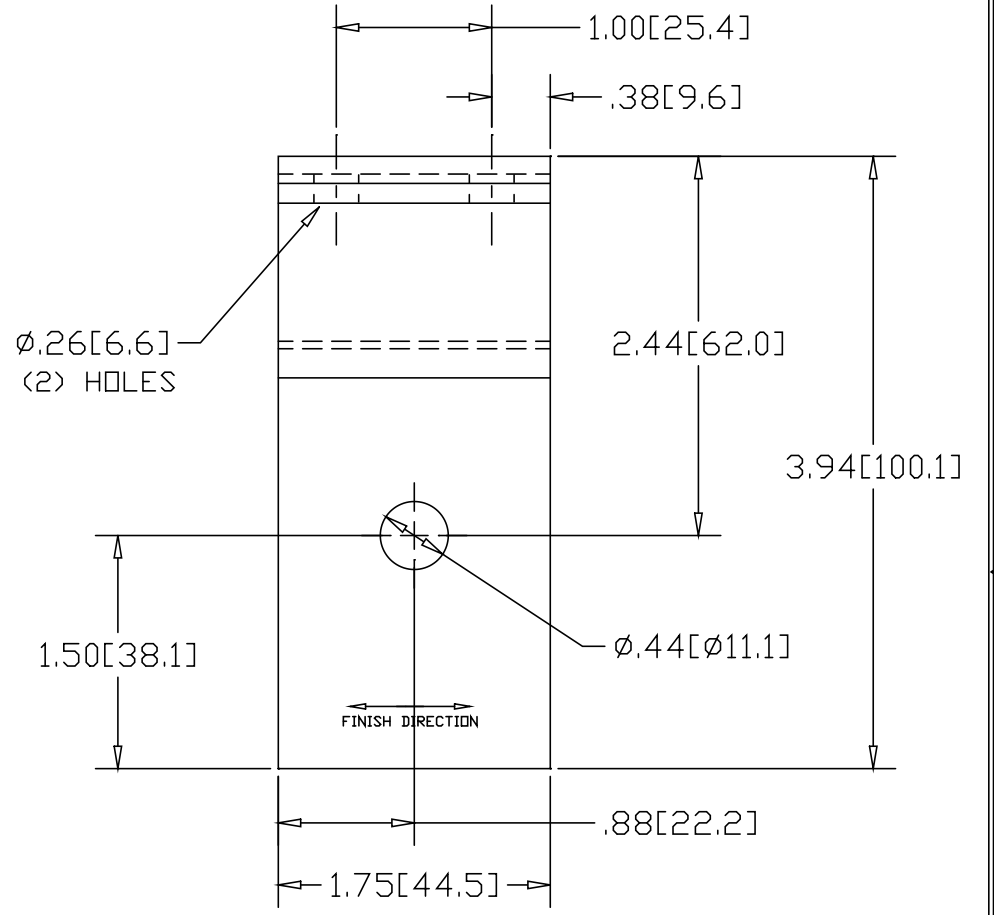

REVISIONS			
REV	DESCRIPTION	DATE	APPROVED
1	ADDED FINISH DIRECTION CALLOUT	10/06/10	PWH

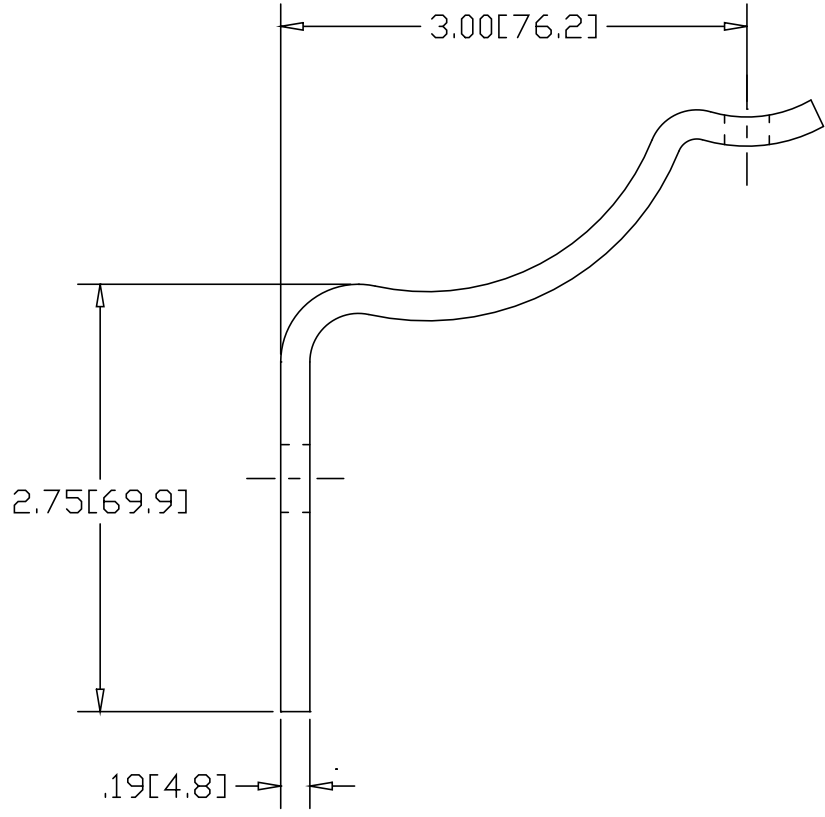

INCHES[MILLIMETERS]

PART NAME		3" EXTRUDED STYLE STAMPED BRACKET		
MATERIAL		7 GA. (304) STAINLESS STEEL ASTM A-240		
DATE	3/25/93	 <b>R &amp; B WAGNER, INC.</b>		
DRAWN BY	RJF			
FINISH	MILL	SIZE	WEIGHT	PART NUMBER
		A	.54 LBS	1998R
				REV 1